

Contents

Section	Page
1.0 Introduction	4
2.0 Site Requirements	5
3.0 Installation	6
4.0 Electrical	8
5.0 Maintenance	9

2.0 Site Requirement

2.1 Information

1. The unit is designed for installation in external walls with a thickness of between 150mm to 315mm. For wall thicknesses upto 650mm an extension kit is available (ref: EXT300).
2. If the unit is to be fitted in a replacement window panel, a mounting kit (ref: E300PFK) must be used.
3. The unit must be sited and connected by a suitably competent person and be in accordance with current UK Building Regulations and I.E.E. Wiring Regulations (BS 7671).
4. The unit is intended for permanent connection to the mains electrical supply.
5. The unit is intended for fixed wiring installation.
6. Wiring to the unit in the UK must be via a switched fused spur. The switched fused spur must have a 3mm minimum contact gap in all poles.
7. Ensure that the mains electrical supply is compatible with the rating label attached to the product.
8. The unit must be sited such that the ambient temperature will not exceed 40° C.
9. Do not site the appliance in the vicinity of excessive levels of airborne oil or grease.
10. If the unit is installed in a room containing a fuel burning appliance, the installer must ensure that air replacement is adequate for both appliances.
11. The unit must not be installed at a level below 500mm from the floor.
12. The internal grille surround must be sited at least 125mm away from any wall or projecting surface (Fig. 3).
13. The external grille of the unit must be sited at least 500mm away from any flue of gas or solid fuel appliances. This is to avoid back flow of gases entering the room.
14. All safety regulations and requirements must be strictly followed to prevent hazards to life and property both during and after installation and during subsequent maintenance or servicing.
15. Ensure the mains electrical supply is switched off before commencing installation or maintenance.

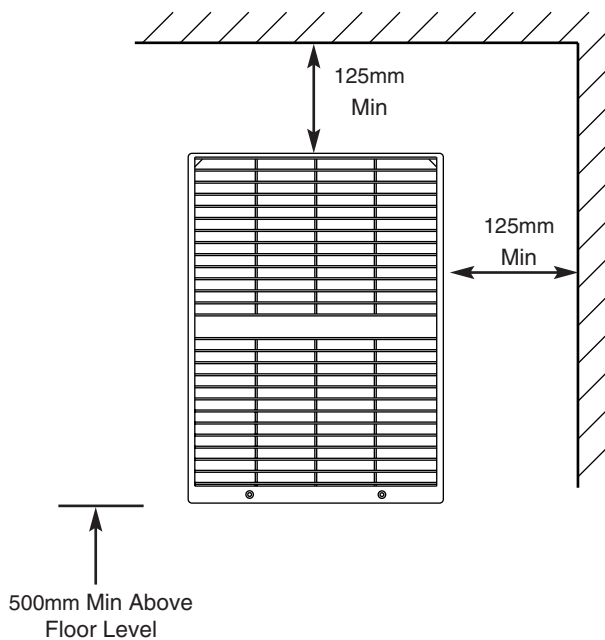

Fig. 3

3.0 Installation

3.1 Controllers

1. The HR300 unit can be installed in conjunction with a number of controllers.

VCON6: The VCON6 controller can be used to provide Off/Low/Normal/Boost/Sensor control. (The HS6 humidistat or TIM2 over-run timer can be used in conjunction with the VCON6 controller to provide automatic control.

VCON5: The VCON5 controller can be used to provide variable speed control.

HS6: The HS6 is a humidity sensor for switching between HIGH and LOW speeds during the daytime according to relative humidity levels.

TIM2: The TIM2 is an overrun timer which can also be used to control the HR300 unit via a remote sensor e.g. Humidity Sensor.

3.2 Initial Preparation

1. Select an approved electrical control arrangement for the HR300 unit (above).

2. After considering the site requirements (Section 2.0), select a suitable site for the unit and controllers and work out the cable runs.

WARNING: Before deciding on the final position for the unit, check there are no buried cables, pipes or obstructions on the outside wall.

Cable requirements: Suitably (Basec or Har) approved three core cable of appropriate current carrying capacity.

3. Install the cable runs and appropriate controllers in conjunction with a fused connection unit. Contact gap must not be less than 3mm.

4. Working from the inside, mark out the position of the mounting hole - 280mm wide x 380mm high (see Fixing Template).

5. Carefully cut the holes in the inner and outer brick courses to form a suitable aperture to receive the unit. Ensure that this is level.

NOTE: Bricks will cut more easily and accurately if a series of holes are drilled close together along the marked lines.

6. Remove the grille, heat exchanger, from the unit (Fig. 4).

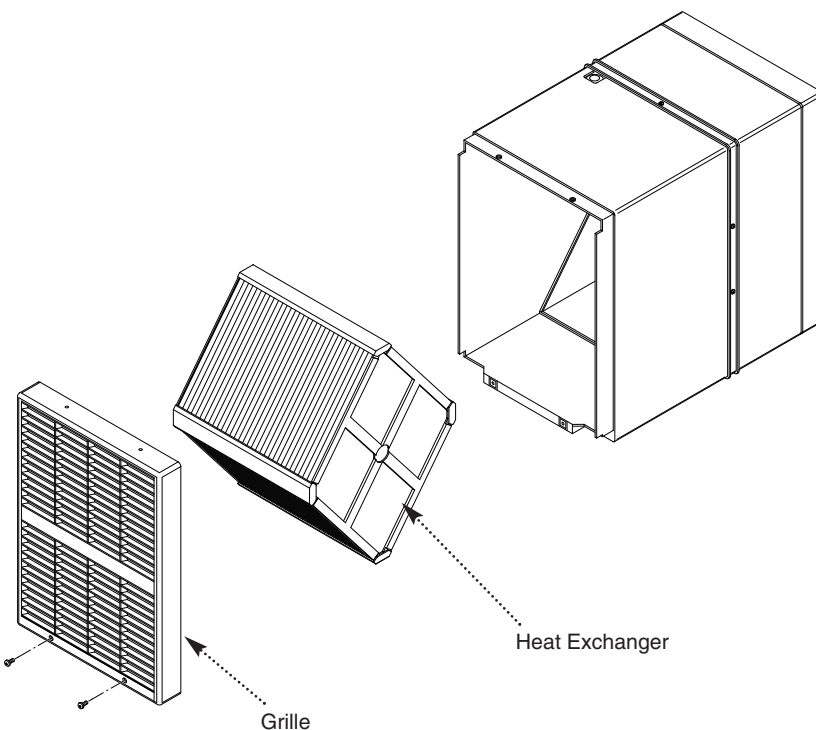

Fig. 4

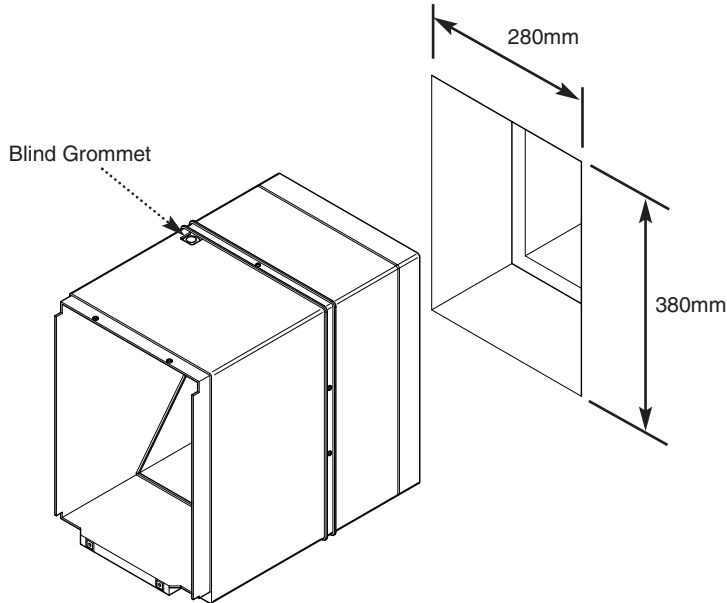

Fig. 5

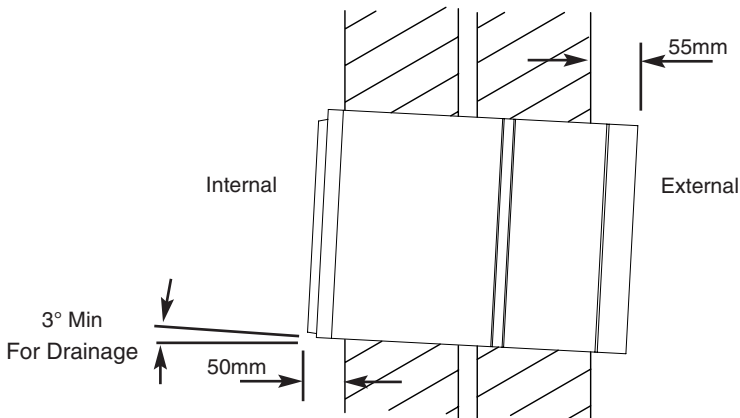

Fig. 6

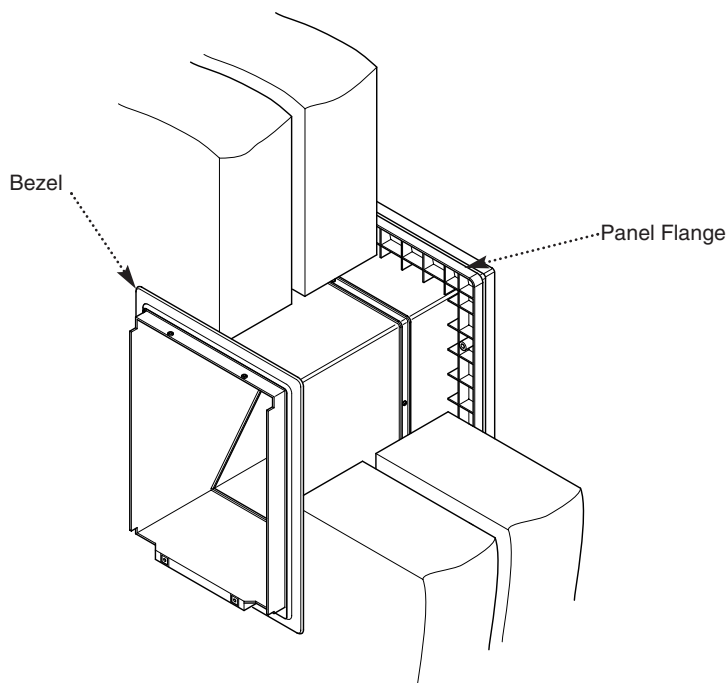

Fig. 7

3.0 Installation

3.3 Installing the Appliance

From Inside

1. Slide the unit into the mounting hole and ensure that the minimum overhang requirements are achieved inside and out (Fig. 5).

2. The HR300 requires an overhang internal and external (Fig. 6):

Internal	50mm
External	55mm

3. Pierce the blind grommet on the left hand side on the top of the unit and feed the supply cable through the grommet (Fig. 5)

4. Ensure that the unit is square and true with the outside wall face. If firmer fixings are required, secure the unit in place with the two fixing screws provided.

NOTE: Ensure the fixings DO NOT inhibit removal or replacement of the heat exchanger.

5. Make good around the case.

6. Fit the bezel on the inside to cover the making good by pressing the bezel over the case (Fig. 7).

CAUTION: Ensure the case does not distort during fixing and making good.

From Outside

1. Slide the panel flange (flange first) on to the unit and press the flange firm against the outer wall (Fig. 7).

2. Secure the panel flange to the wall using the fixing screws provided. If necessary the panel flange can be secured to the case by self tapping screw 25mm long maximum.

4.0 Electrical

4.1 Electrical Connections

230V 50Hz 108W max

1. The HR300 is supplied with an integral shutter device.

2. Wiring must be via a 3A fused switched spur with a 3mm contact separation in each pole. The wiring should be suitably (Basec or Har) approved cable of appropriate current carrying capacity.

3. Ensure that the mains power supply is isolated prior to installation.

4. Remove the plug from the socket and connect incoming wires to the appropriate terminals (Figs. 7 & 8).

5. Replace plug into socket.

6. Slide the heat exchanger into the unit (Fig. 9).

7. Locate the grille on to the front of the unit and secure with the two screws provided (Fig. 9).

NOTE: Ensure the controller to be used is wired in accordance with the instructions supplied with the controller.

8. Switch on the mains electrical supply and check the operation of the unit.

NOTE: On operation there is a delay of 30 seconds prior to the shutter opening.

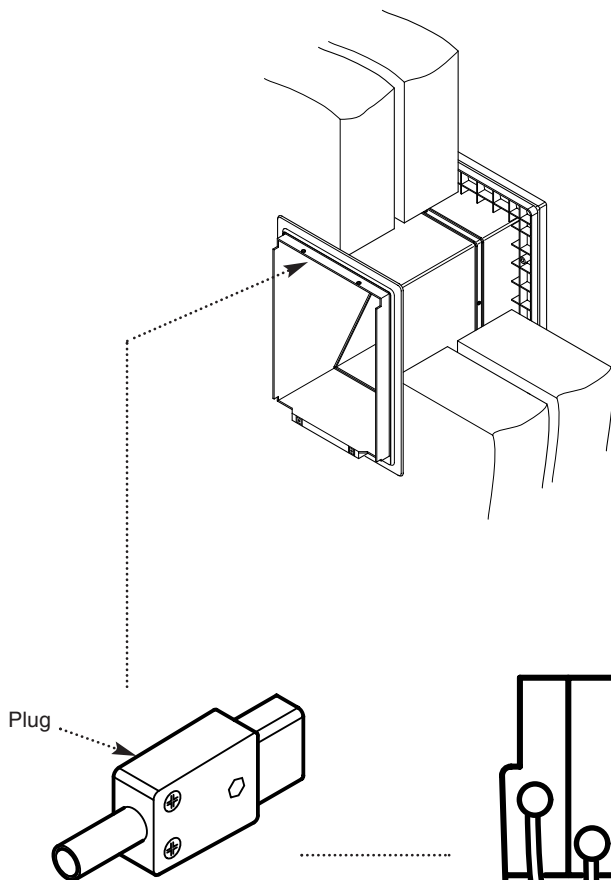

Fig. 7

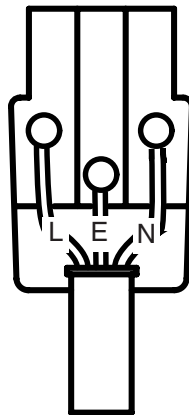

Fig. 8

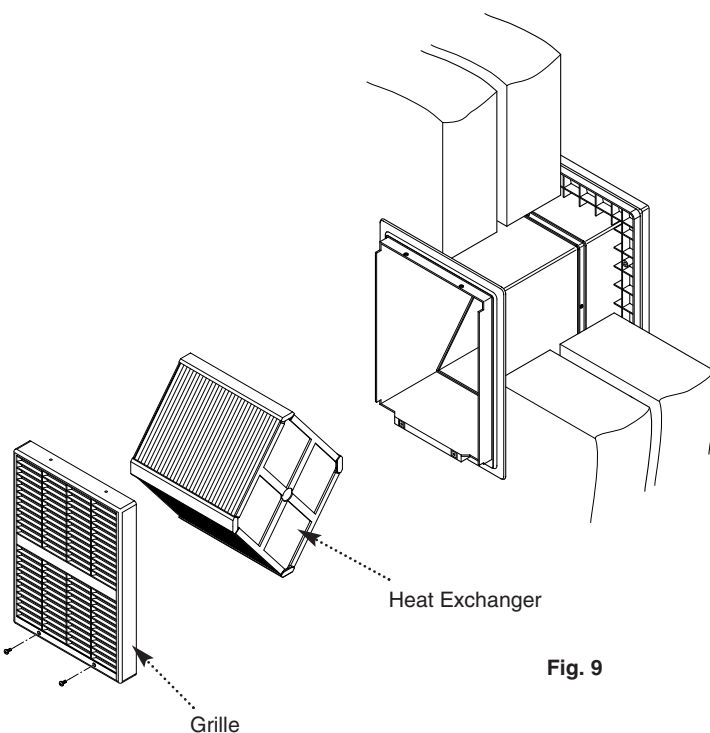

Fig. 9

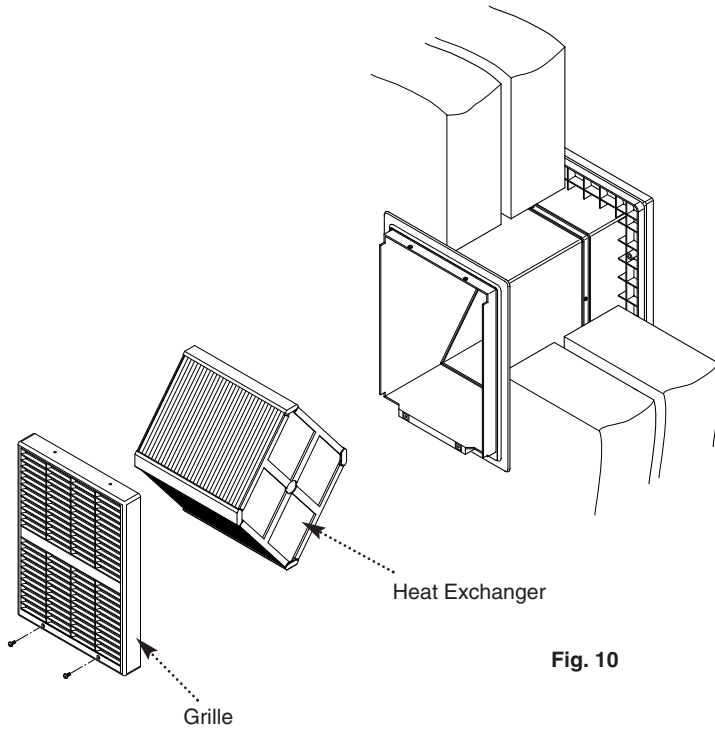

Fig. 10

5.0 Maintenance

5.1 Cleaning the Unit

1. In addition to removing odours, providing fresh air and recovering heat, this unit extracts airborne impurities such as dust, dirt and grease. These gradually build up and detract from the efficiency and appearance of the unit.

2. To ensure optimum performance, the unit should be cleaned every 3 to 6 months or at periods determined by the level of contamination experienced and according to the following procedure.

3. Isolate the mains power supply.

4. Undo the two grille securing screws and remove the grille (Fig. 10).

5. Remove the filter from rear of grille.

6. Slide out the heat exchanger (Fig 10).

7. Wash the grille, filter and heat exchanger in warm water using a mild detergent and dry thoroughly.

CAUTION: Keep water away from all electrical components and wiring within the unit.

8. If the filter cannot be cleaned, a replacement is necessary (ref: HR300RF2).

9. Reassemble in reverse order ensuring the filter and heat exchanger are seated correctly.

10. Switch power supply on and check the operation of the unit.

Vent-Axia[®]

Clean Air Systems

A Division of Vent-Axia Limited.
Fleming Way, Crawley, West Sussex RH10 9YX
Technical support:- 01293 526062 Fax:- 01293 539209
Internet Site at:- www.vent-axia.com