

# ***COVERSTAR***



## **INSTALLATION** **INSTRUCTIONS**

Revision	Date Modified
1	3.10.02
12	5.5.05

# **INSTALLATION INSTRUCTIONS**

Please read these installation instructions carefully before you start work.

## **(A) ENCAPSULATED UNDERGUIDE**

1. Track installation
2. Mechanism installation
3. Cover installation
4. Lid installation
5. Final adjustments
6. Pit diagram
7. Track cross sectional diagram

## **(B) DECKMOUNT AND RECESSED TOP GUIDE:**

1. Track installation: a) surface mounted and; b) flush mounted
2. Mechanism installation a) deck and; b) pit mounted
3. Cover installation
4. Final adjustments
5. Pit drawing
6. Track cross sectional diagrams

## **OTHER:**

1. Pit bracket in-situ
2. Slider type drawing
3. Rope path diagram
4. Troubleshooting
5. Wiring Diagram



# Pre-installation Check List



Before your Coverstar is delivered please ensure that you are able to tick yes to all of the following questions.

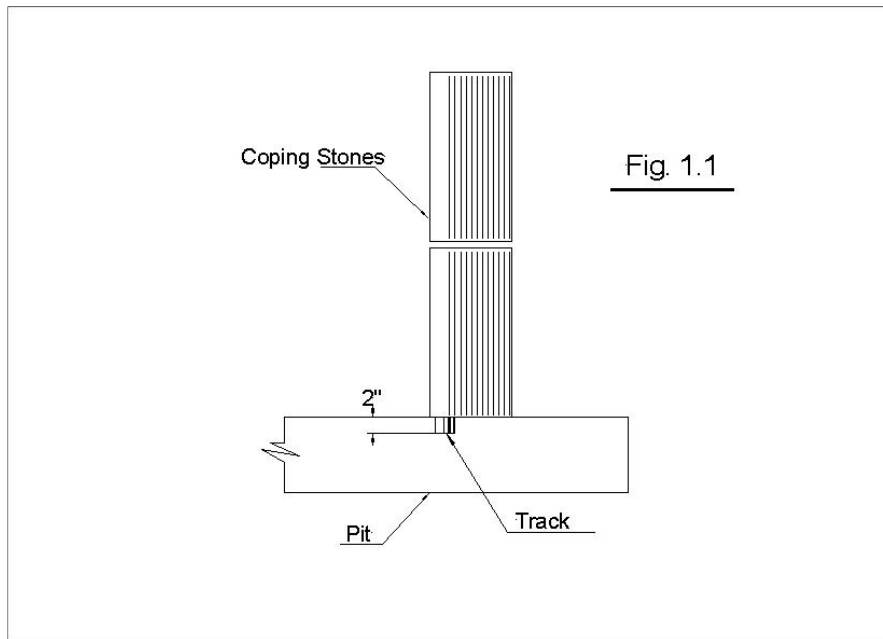
PLEASE CHECK	YES	NO	N/A	COMMENTS
Is the pool construction finished?				
Is the water to its final fill level?				
Is the surrounding decking/paving level and solid – will it offer a secure fixing base? <i>There must be at least a 3" concrete base to fix to.</i>				
If encapsulated under guide, have the encapsulation and guide been built into the pool wall?				
If flush guide, have the channels been set/dug at the correct depth and parallel spacing?				
Is the bed under the channel and the base of the pit solid?				
Recessed pit: has the pit been built to the correct size: - pool length up to 40ft pit: 12 inches <sup>2</sup> ; 40 to 50ft: - 13 inches <sup>2</sup> ; over 50ft: - 15 inches <sup>2</sup>				
Is the pit clean and the walls & base smooth?				
Has a drainage point been fitted into the pit?				
Have conduit and draw cord been installed for the hydraulic hoses?				
Is the ordered hydraulic hose length still correct? (Check original order form)				
Is there suitable space/positioning for the hydraulic pump/motor?				
Is there a power supply to the hydraulic pump/motor? Will a separate power supply be available for use?				
When the key switch is positioned, will the full operation of the cover be visible?				
Can a member of your staff be made available on the installation date?				
<b>Electrical requirements:</b> 20 amp breaker in the plant room for the hydraulic motor, in conjunction with current wiring regulations.				
Is there a socket for the cover pump, within 8 metres of the pool?				
Is there a mains outlet to plug in power tools?				
<b>Panel pools only:</b> Does the dividing wall panel have brickwork (3" minimum) behind to act as an anchor for the mechanism mounting?				
Any additional comments:				

**Enquiries to Certikin Pool Technical office on 01993 777200**

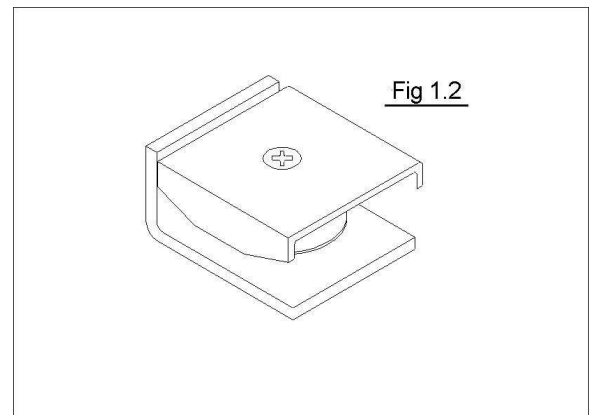
## (A) INSTALLATION INSTRUCTIONS

### 1. Track Installation (Easiest to install before pool is plastered) (Also applicable to Linerlock Encapsulation )

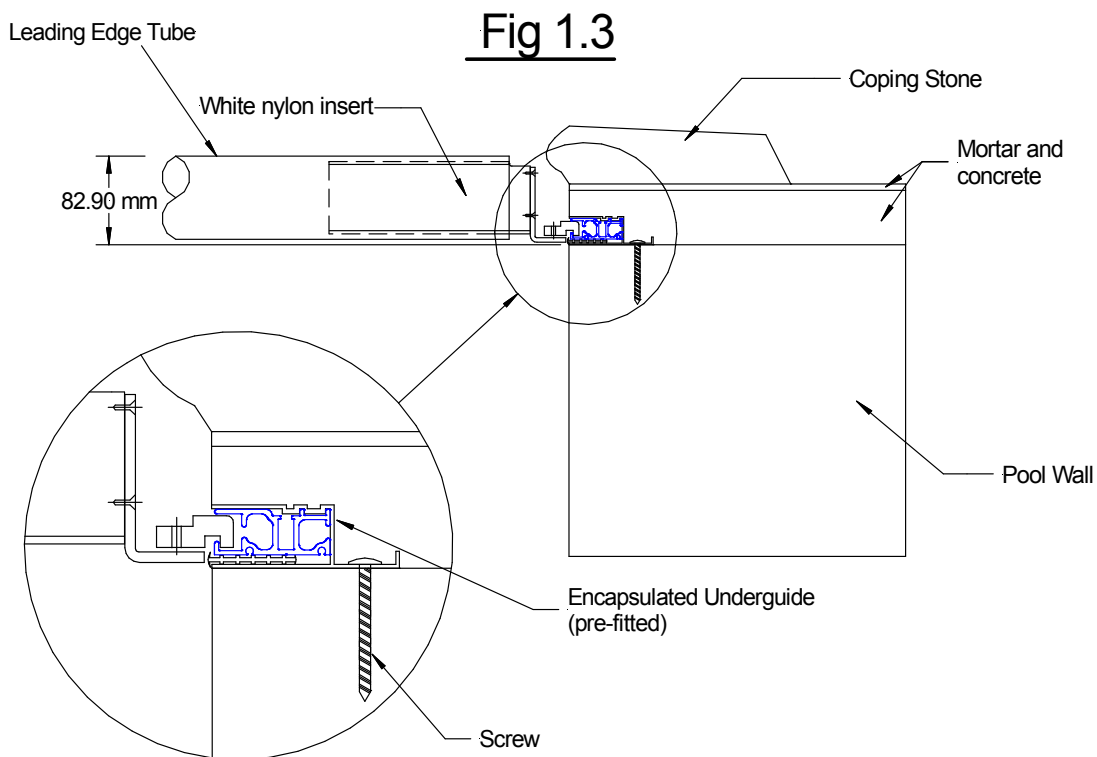
- ❑ Check all pool dimensions, including track lengths, widths and diagonals. This information will help with installing the unit in the best manner possible. If the track space varies by more than 1" (25.4mm), do not proceed with this installation until you have talked to your Coverstar distributor.
- ❑ Check the underside of the coping on each side. Make sure that there is no grout or cement hanging down which will not allow the tracks to be mounted flush with the bottom of the coping.
- ❑ Lay the Encapsulation on the deck where they will be installed. Starting from the pulley ends place the side with the open face facing the pool and the flat side of the Encapsulation at the bottom. If the track is too long, mark and cut as appropriate. (Linerlock Encapsulation should be cut to a mitre at the opposite end to the pit, see Fig 1.4a)
- ❑ The tracks should extend into the cover pit approximately 2" (50mm) (see Fig 1.1) and 2" at the opposite end for the pulley (see Fig 1.4 – page 6).



- ❑ The last track length must be at least 4' (1.22m) long and have at least two holes in it to secure it to the deck. The last hole in the track should be within 4" (101.6mm) of the dividing wall. Since all tracks are originally the same lengths, the two cut pieces should also be the same lengths. If they are not, stop and investigate why.
- ❑ File the sharp edges from the tracks at all the joints.
- ❑ Lay encapsulation containing track and spacer on top of the wall. Remember to leave sufficient overhang on the front edge of the track to allow for tiles/ screeding yet to be laid.

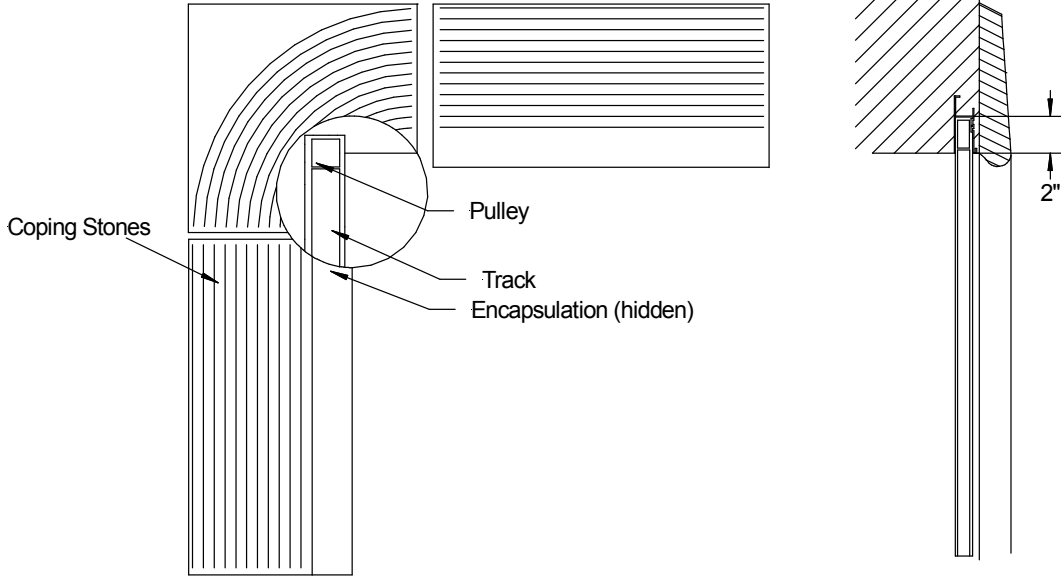


- ❑ Slide track splices into the centre slot of the tracks at each joint. They should extend equally into each track.
- ❑ Mark out drill points along the back edge of the channel approximately 2ft (600mm) apart. Drill through 7mm clearance holes.
- ❑ Use a 1/4" (6mm) masonry drill bit (preferably in a hammer drill) to drill through each clearance hole to a depth of 3" (77mm). Drill on a slight angle toward the pool wall. This helps prevent the deck from breaking out when the screw is tightened in the anchor. In addition, it is usually best to avoid drilling in or near grout lines, as a strong anchor is required. Note: If the hole is not drilled deep enough, it is possible to break the concrete when the screw is tightened.
- ❑ Using fixings provided, fix the track down to the deck (Fig 1.3).

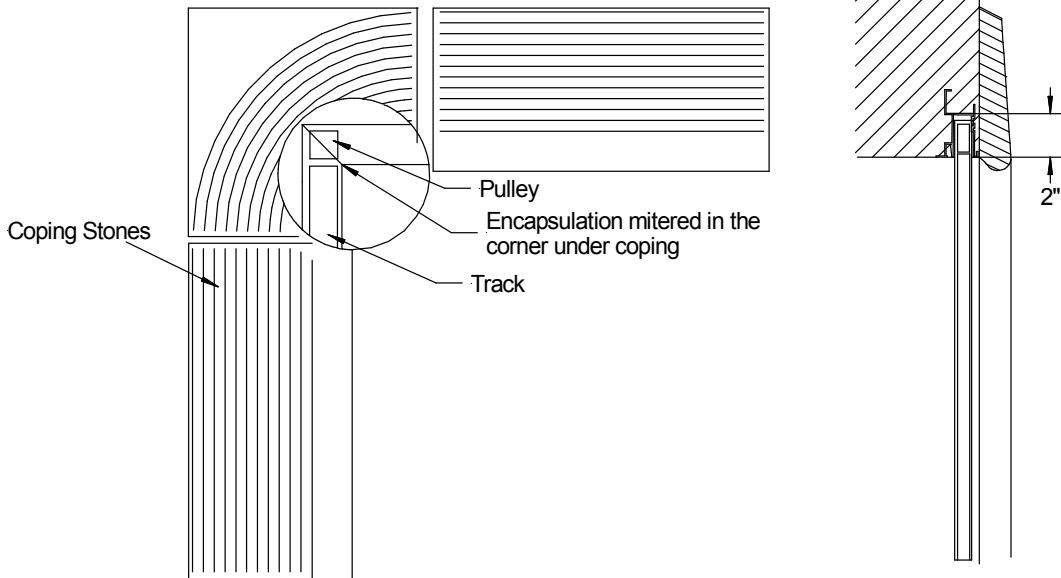


**N.B. Please ensure no debris is able to get into the tracks, for example: small stones, cement, etc. It is essential the tracks are kept free to allow the cover to run properly.**

**Fig 1.4**

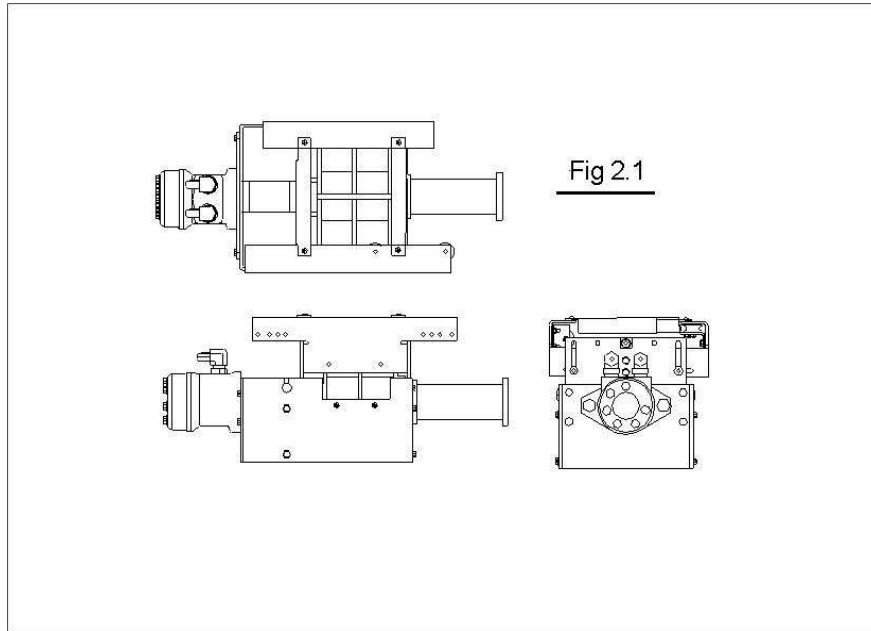


**Fig 1.4a - Linerlock Encapsulation**

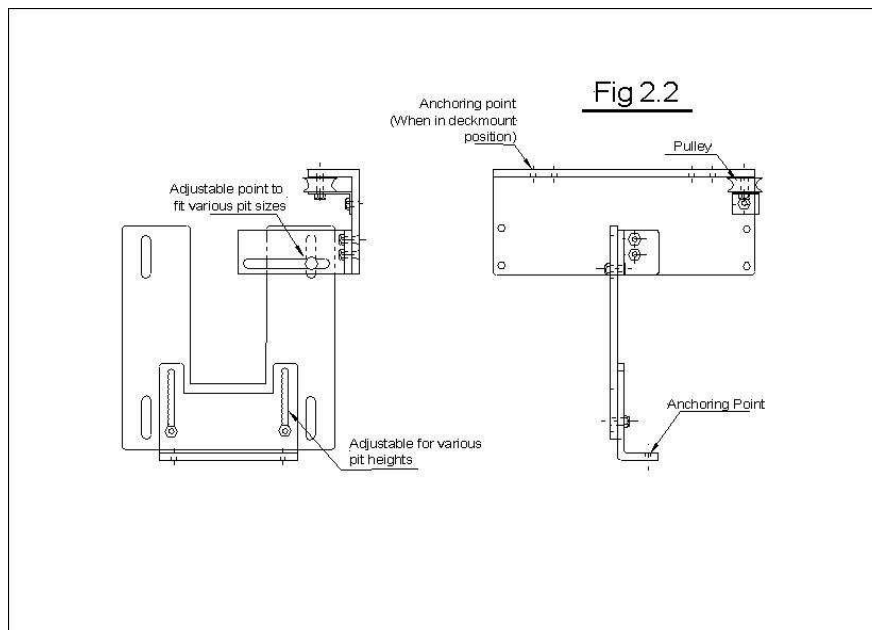


## 2. Mechanism Installation

- ❑ Measure the track space and check it against the order.
- ❑ Place the rollup tube between the drive mechanism (Fig 2.1) and the freewheel end assembly (NME) (Fig 2.2) and connect all three components using the 3/8" x 1 1/4" bolts and washers provided.



- ❑ Place the newly assembled tube and mechanisms into the pit. You are now ready to set the assembly in the pit.
- ❑ Adjust the bottom brackets on the drive mechanism side. The two adjustable brackets on the NME are set after the mechanism is mounted:



- ❑ Centre the assembly in the pit from front to back. Align the drive end with the track by taking a short length of rope and extending it from return side of the track to the pulley at the back of the mechanism. Position the mechanism so that the rope will come out of the track and directly onto the pulley at the back of the mechanism (for details on which is return side and the correct pulley, see the rope path diagram).

**Tip!** Check the NME and make sure the return side of the track lines up directly with the pulley on the bracket. If it does not, you can make minor adjustments by splitting the difference between the two sides. However, if it is out of alignment by more than 1", call your distributor for help. Installing a misaligned unit could result in improper operation of the unit.

- ❑ With the mechanism in the correct position in the pit, and the track and pulleys in line as described above, secure the mechanism assembly in place by drilling through the pre-drilled holes and using the fixings supplied. It is essential that the mechanism be anchored to a strong base. If there is any adverse movement in the assembly, it must be rectified before carrying on with the rest of the installation.
- ❑ On a cover 45' or less, the back pulley bracket should be level with the track. If it is not, raise the unit by placing shims underneath it. This will reduce the stress on the unit by reducing the angle at which the rope travels.
- ❑ Loosen the bolts on the adjustable pulley brackets on the drive and non-drive ends to allow movement from the front to back walls of the pit. Secure the top brackets on both ends so that they are touching the walls and re-tighten the bolts.
- ❑ Secure the brackets in position using the pre-drilled holes as pilot holes. Fix to the walls using the fixings supplied.
- ❑ Using the draw cord that should be threaded through the ducting from the plant room to the drive end of the pit, pull the hydraulic hoses through and fix them to the fittings on the drive mechanism.
- ❑ At this point an approved electrician should wire the hydraulic motor into the mains using the wiring diagram supplied.

N.B. Check for the following:

Are the ropes level as they travel from the tracks to the pulleys?

Does the roll up tube make a right angle with the tracks?

Is the unit mounted centrally in the pit?

Is the roll up tube level in the pit?

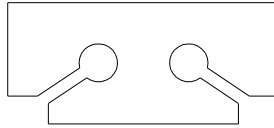
### 3. Cover Installation

- Unroll the cover on the deck behind the mechanism so that the topside is facing up. Make sure the leading edge loop is on top.

**Tip!** At the factory, the cover is rolled from left to right. Therefore, always placing the cover on the left hand side (standing behind the pit) and rolling to the right will ensure the cover is positioned correctly.

- Feed the rope into the black rope feed guide (Fig 4.0):

**Fig 2.3** (End view)



- Pull the rope through the rope feed guide at the pit end of the track and thread the rope on the mechanism as per the rope path diagram.

**Tip!** It may be easier to feed the rope into the track by pushing a piece of thin wire into the rope. Using this method, the rope can be pulled through the track channels and around the end pulley quickly and stay in the track.

- Repeat the rope threading procedure for the non-drive end.
- Feed the leading edge tube into the front loop of the cover.
- Fit the white nylon slotted leading edge inserts into the ends of the leading edge tube.
- Remove the rope feed guide from the end of the track and feed it onto the front corner of the webbing. Push the slide assembly into the poolside channel of the track.
- Feed the cover guide that is attached to the cover just behind the sliders into the track. Place the tuning fork cover stops on the end of the tracks. Drill through the rope feed guide and track with an 11/64" (4.5mm) drill bit. Fix the rope feed guide to the track with a 1" x 10 self-tapping screw (as supplied).
- Pull both sides of the cover approximately 6"(152.4mm) into the tracks. It is important that both sides are into the tracks the same amount.
- Go to the rope reels. Pull all the slack in the ropes out of the front of the unit so that the ropes are tight through the guides and the loops. Before cutting the ropes be sure the cover is into the tracks about 6"(152.4mm) and is even across the front of the housing. Pull the ropes so that they just move each end of the leading edge. Put them together and ensure you have a minimum of 6' (1830mm) of rope to wrap around the reel. Now cut the rope. Heat the ends of the rope or wrap it with electrical tape to prevent fraying.

**Tip!** Both ropes are cut the same length at the factory, so that the rope returning on the drive end will be too long by the width of the pool. Before cutting the ropes, make sure that the cover is no further than 6"(152.4mm) in the tracks.

- Using the 1/2" pan head screws supplied, screw through the rope about 1" on the drive side and 2" on the NME (this compensates for the stretch that may occur in the longer section of rope from the NME). Screw into the tapped holes in the respective rope reel sides.
- While holding the ropes, run the cover to the 'closed' position to wind the ropes onto the reels. (When you run the cover at this point, the leading edge should begin to move at exactly the same time on both sides of the pool – if not, adjust the position of the screw in the rope on the side that started last.)

**Tip!** It is OK if the NME side of the cover starts slightly ahead of the drive side as it allows for any stretch that may occur in the rope. However, it should not be more than 1" ahead.

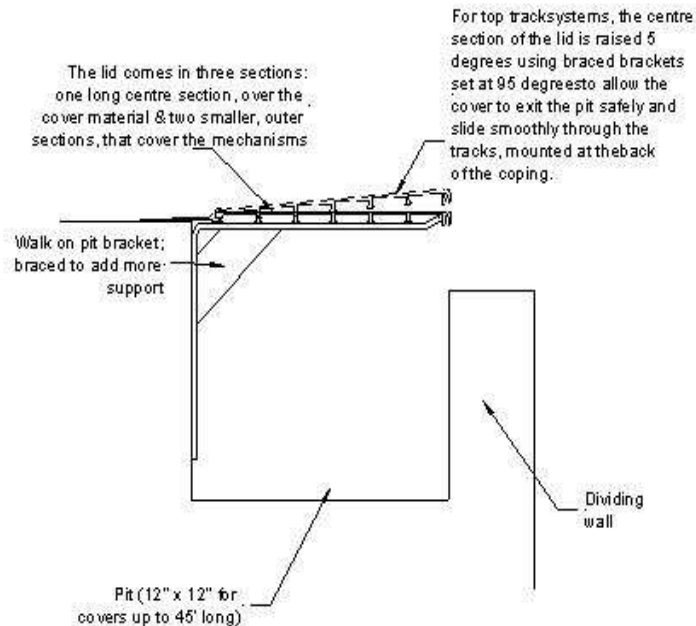
- Run the cover out over the pool.
- At the pit end, the end of the cover will be ready to be attached to the roller. Place the cover 1 1/2" over the end of the tube so that the outside lines up with the tracks on each side.

- Approximately 2½” from the end of the roller, fix the cover to the roller with the 5/8” screw provided. Use the seam on the roller as a guide to keep the cover straight.
- Gather all of the slack to the middle of the cover. Find the middle of the cover and fix it to the centre of the roller, using the screws provided.

### 3. Cover Installation (cont)

- Disperse all of the slack equally on either side of the centre hole in the roller. Fold the slack over to form a pleat and screw it to the roller.
- Using the screws remaining, fix the remaining sections of the cover to the roller equally, remembering to use the seam as a guide for straightness.
- Run the mechanism in the uncovered position so that the excess cover material is rolled up around the roll up tube. The material is now installed.

#### Coverstar Standard Aluminium Lid



## 4. Heavy Duty Pit Lid Installation

- ❑ Space the stainless lid mounting support plates 2' apart along the back edge of the pit. Two welded studs should protrude into the pit.
- ❑ Secure by drilling through the pre-drilled holes into the deck surround with the screws and Rawlplugs provided.
- ❑ Fix the aluminium brackets to the support plates using nuts and washers provided. These brackets can be height adjusted to suit the type of pit covering being installed.
- ❑ Make sure the rope is tight across the back of the pit. Mount the black rope loops to the back wall of pit using the screws and plugs provided, ensuring the rope remains straight from pulley to pulley.
- ❑ Ensure the brackets are all level.

### Aluminium lid procedure

- ❑ Assemble the lid by sliding the hinge onto the main lid sections.
- ❑ Position the lid over the top of the pit. The drive end and NME should overlap about 1" on both ends. If they overlap more, it may necessary to cut the lid.
- ❑ Drill through the lid along the back edge of the hinge every 2'-3' using a ¼" (6.5mm) drill bit.
- ❑ Fix the lid to the pool surround using the plugs and screws provided.
- ❑ Check for any sharp edges, file as necessary.
- ❑ When the lid is in the closed position, ensure each supporting bracket is in contact. If any are not, it maybe necessary to adjust the bracket.

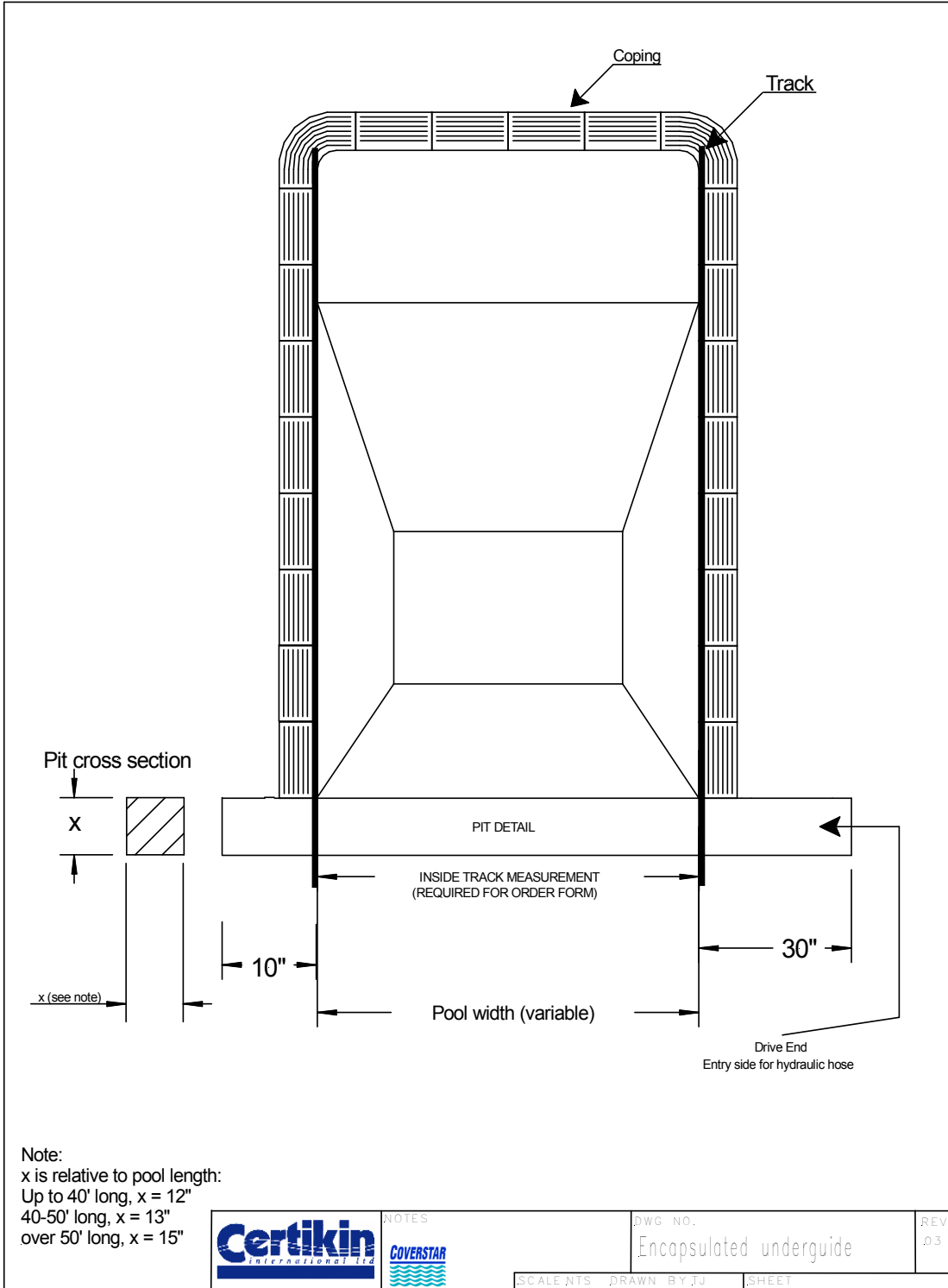
N.B. See page 27 for details on the pit bracket installed.

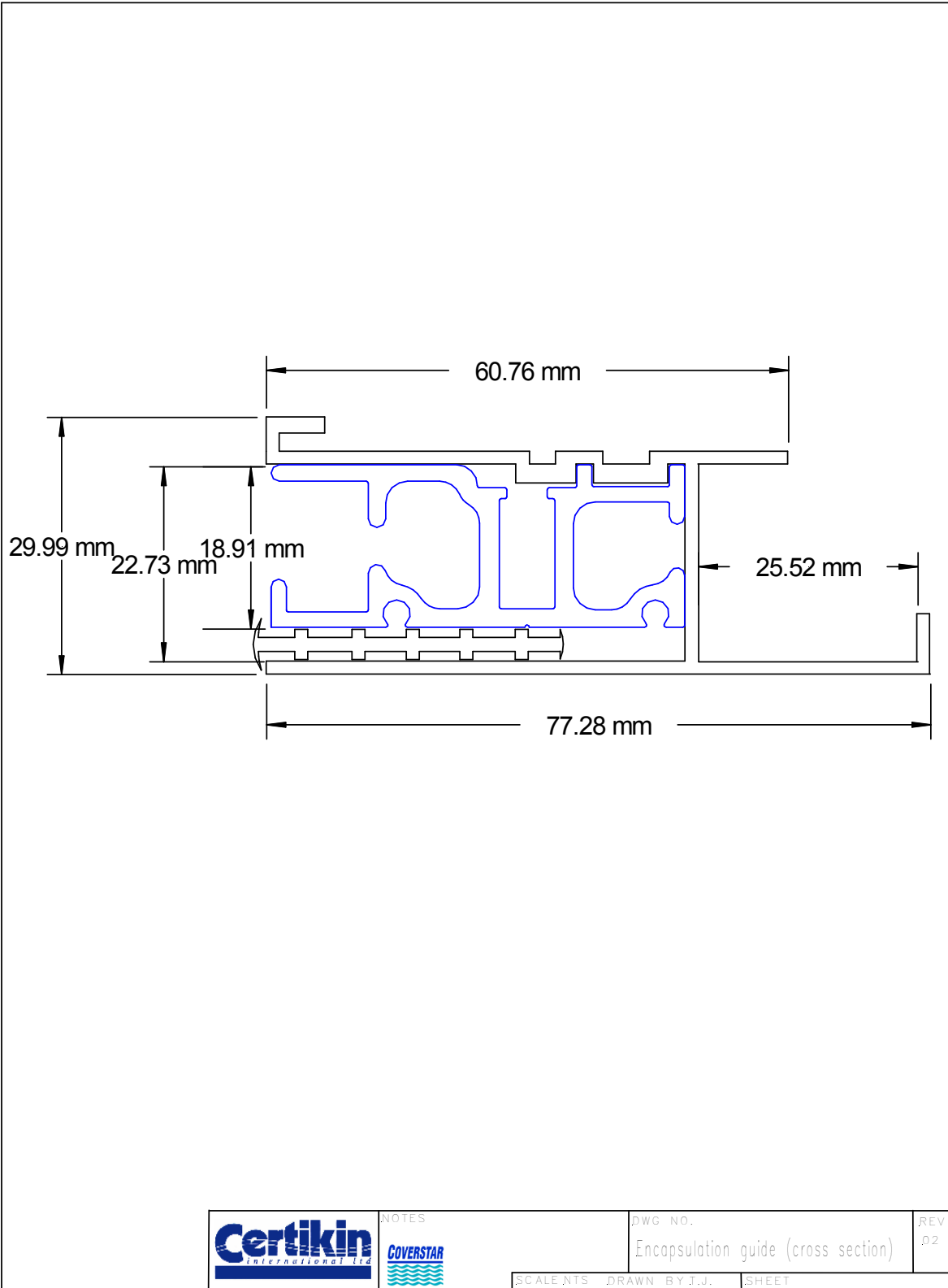
## 5. Final Adjustments

- ❑ Check the brake mechanism on the rope reels. The rope reels should have enough friction to prevent them from freewheeling when running under stress. Note: The tension on the brackets is preset at the factory and normally will not need adjusting.
- ❑ Run the cover back and forth over the pool several times (at least 6 times to get any stretch out of the rope), making sure that it is operating properly. If necessary, make adjustments so that the cover is going out evenly and that it is operating smoothly.
- ❑ Ensure area is clean and tidy upon completion of work.

## Instructions to Homeowner

- ❑ Instruct the homeowner on how to operate the cover with the key and how to stop the cover in the proper position.
- ❑ Instruct the homeowner on the use of the cover pump that should be in place at all times on the cover in an operating mode.
- ❑ Inform the customer to watch the introductory video.
- ❑ Review the owner's instructions with the homeowner, and have them sign a worksheet stating they have been instructed and the installation has been completed to their satisfaction.



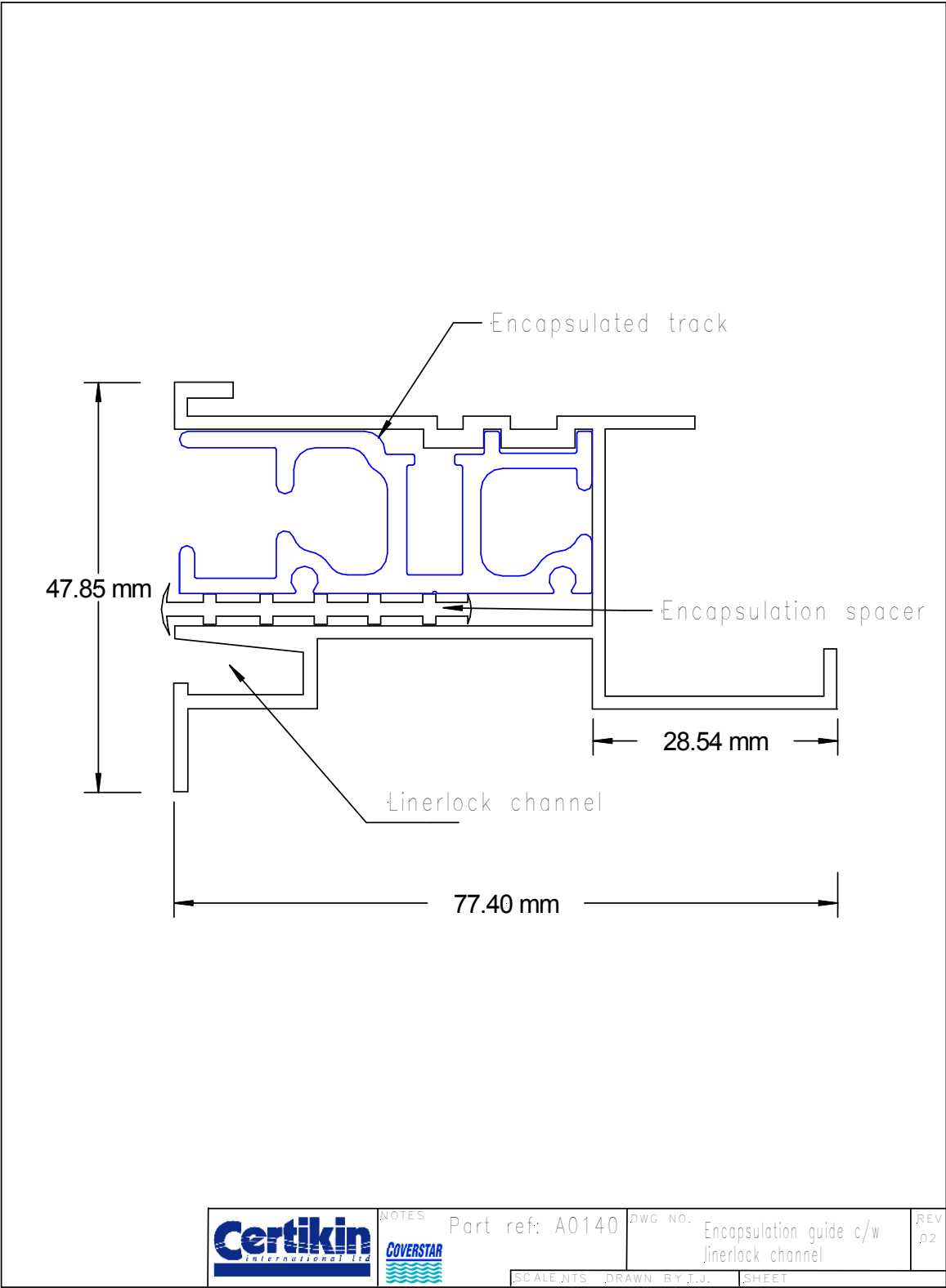


NOTES  
COVERSTAR

DWG NO.  
Encapsulation guide (cross section)

REV  
02

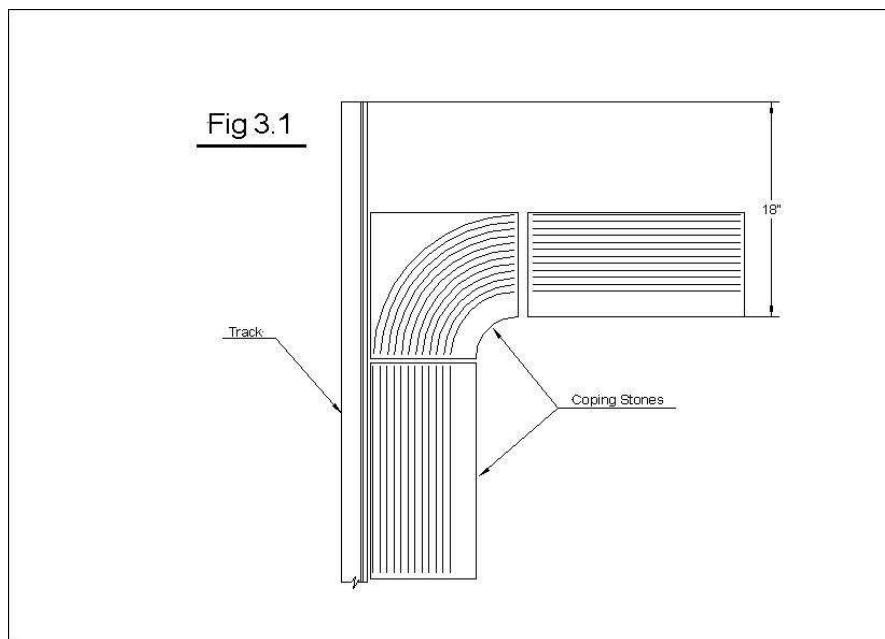
SCALE: NTS DRAWN BY: J.J. SHEET



## (B) INSTALLATION INSTRUCTIONS

### 1a. Deckmount Track Installation

- ❑ On the mechanism end of the swimming pool, mark where the tracks will go. The end of the tracks should be positioned no more than 18" back from the edge of the pool. The track space must be the same as was ordered. If it varies by more than the 1" (25.4mm) tolerance issued by Coverstar, stop at this point and contact your Coverstar distributor. Do not proceed with the installation. The cover will not operate properly if it is not installed as ordered. An improper installation may void the warranty.
- ❑ From the marks on the deck, make a pure rectangle. Make chalked lines perpendicular to the track starting points that extend past the pool at least 18" (Fig 3.1).



- ❑ Make a small mark on each line that is 18" past the end of the pool. Make sure both lines are the same lengths from the mechanism end to the far end of the track positions. Measure the diagonals from corner to corner. They must also be equal.
- ❑ Starting at the pulley end, lay the tracks along the chalked line. The grooved side of the track should be facing the pool. The tracks should be the correct size (as ordered). If they are too long, mark and cut as appropriate.
- ❑ File any sharp edges or burrs from the tracks.
- ❑ Use splices at any joints in the tracks. Slip them into the centre slot of the tracks at each joint so they extend equally into each.
- ❑ Ensuring tracks are perfectly straight along the chalked lines on either side of the pool; fix the tracks to the pool surround using the pre-drilled holes in the track. Screws and plugs are supplied in the systems pack.

**Tip!** Stand on the track as you drill through it to hold it in place. Also make sure you drill down 3" (76mm), as it is essential the tracks have a good anchoring. Therefore, if the bed you are drilling into is not adequate, work must stop and action taken to lay a decent bed of concrete.

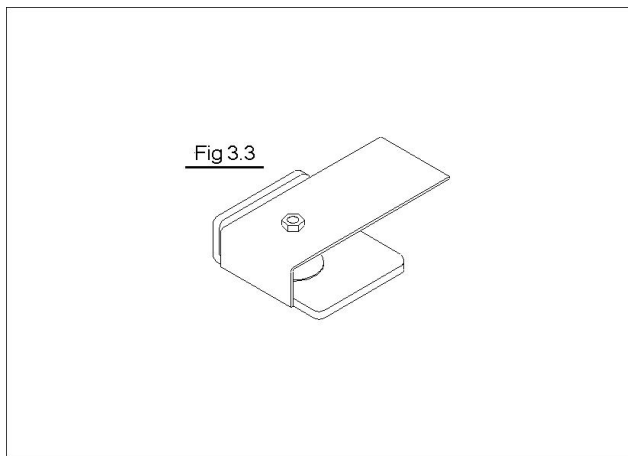
- ❑ Using the screws (1 $\frac{3}{4}$ " x 8) and plugs supplied, fix the tracks down to the pool surround. Only half-tighten the screws, as it will not be possible to run the rope through the track channels.
- ❑ Place the pulley end caps (Fig 3.2) on the end of the tracks so they overlap as far as possible. Mark through both holes and drill  $\frac{1}{4}$ " (6.5mm) into the deck. The end caps will be mounted after the cover ropes are pulled through them.

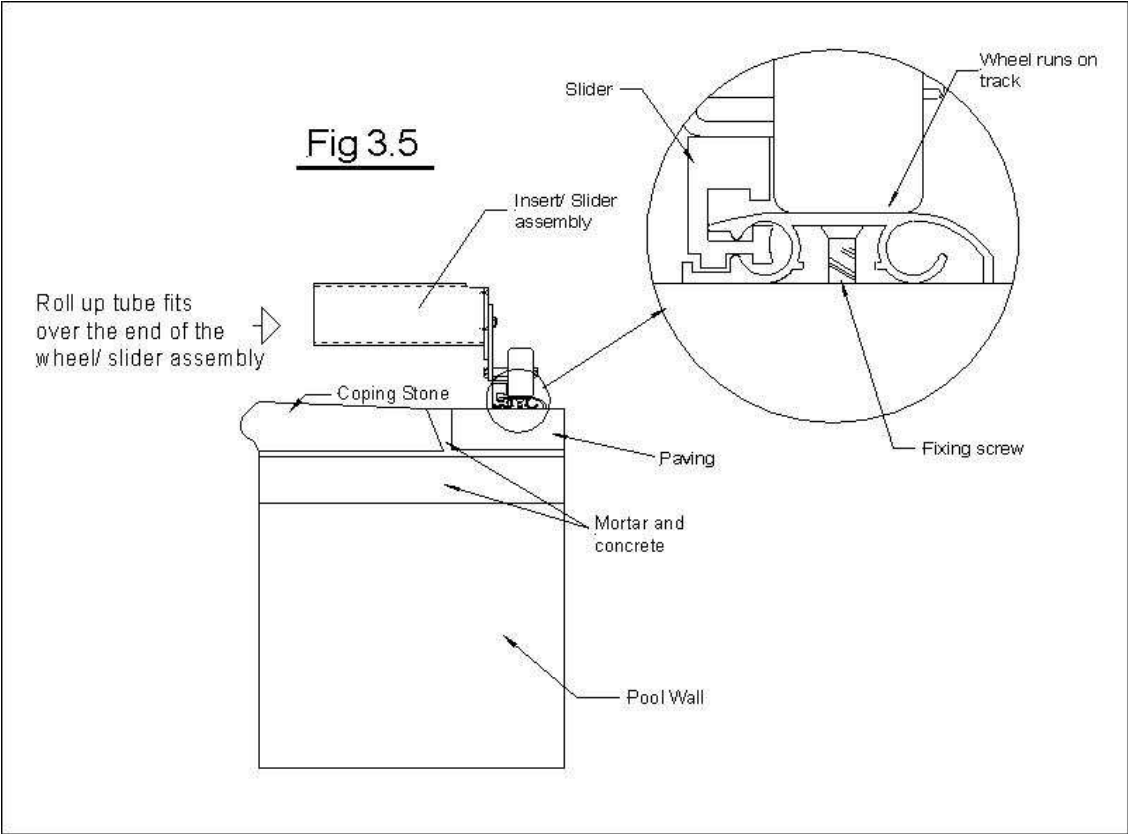
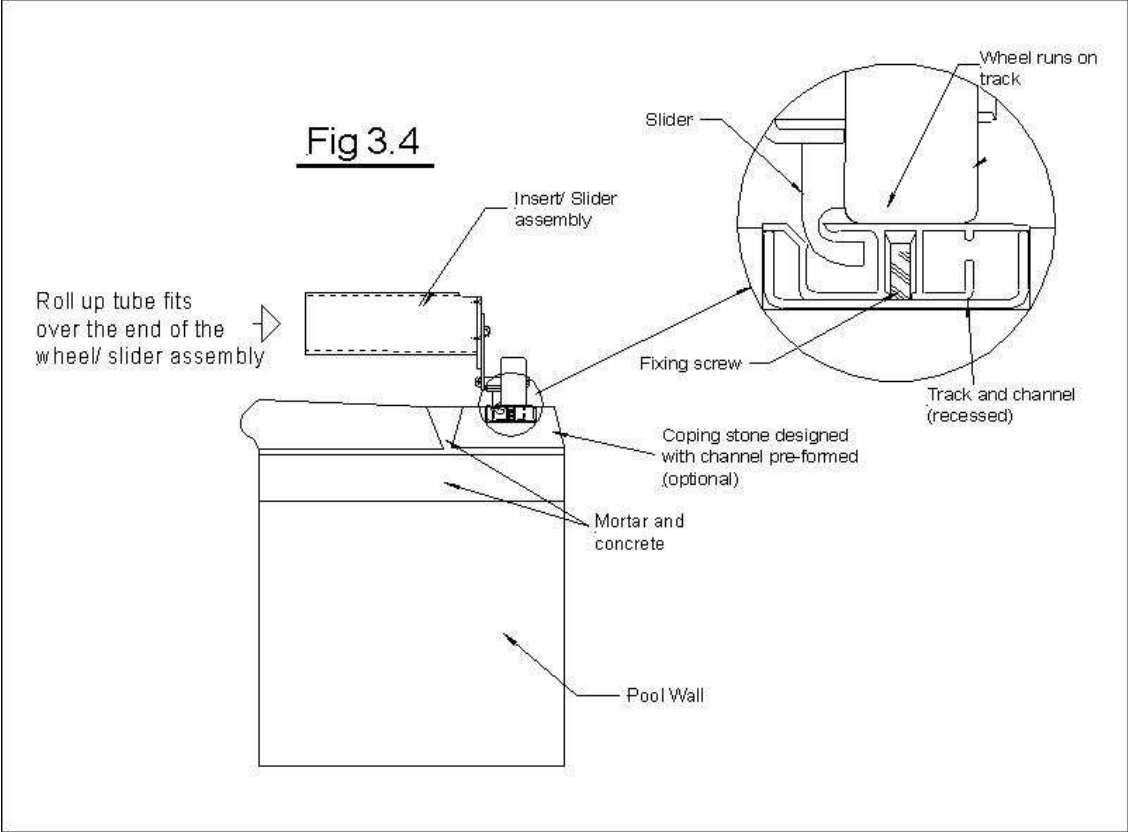


### 1b. Flush mounted track

When preparing the pool surround for a flush track system, the following points must be observed:

- ❑ The channel that the track will be seated in should be ready to accept the track size, as detailed in the drawing in this manual.
- ❑ The channels should be in accordance with the order form supplied to your Coverstar distributor, i.e. distance between tracks and track length should be correct.
- ❑ The base of the channel should be level; any deviance can result in the tracks not being installed properly.
- ❑ The track and end pulleys (Fig 3.3) should finish flush to the deck surround when fitted (Fig 3.4).





## 2a. Deckmount Mechanism Installation

- Place the drive mechanism and freewheel end (NME) on the deck next to their positions.
  - Place the roller tube between the drive mechanism and NME and attach using the 3/8" x 1/4" bolts and washers provided.
- Tip!** Spread the two pulley brackets to 2" wider than the mechanism body. This allows easier access to the pulleys for threading the ropes.
- Set the assembly where it will be finally mounted. Then using the pre-drilled holes in the mechanism base, fix the assembly down to the deck with the screws and plugs provided. (As with the tracks, it is essential that the base the mechanism is anchored to is strong enough. If there is any adverse movement, it must be rectified before carrying on with the rest of the installation).
  - Check the level of the roller tube. Adjust the brackets on the mechanisms to suit.
  - Using the draw cord that should be threaded through the ducting from the plant room to the drive end of the pit, pull the hydraulic hoses through and fix them to the fittings on the drive mechanism.
  - At this point an approved electrician using the wiring diagram supplied should wire the hydraulic motor into the mains.

## 2b. Pit mounted Mechanism Installation

- Place the drive mechanism (DM) and freewheel end (NME) on the deck next to their positions.
  - Place the roller tube between the DM and NME and attach using the 3/8" x 1/4" bolts and washers provided.
  - Place the newly assembled tube and mechanisms into the pit. You are now ready to set the assembly in the pit.
  - Adjust the bottom brackets on the drive mechanism side. The two adjustable brackets on the NME are set after the mechanism is mounted.
  - Centre the assembly in the pit from front to back. Align the drive end with the track by taking a short length of rope and extending it from return side of the track to the pulley at the back of the mechanism. Position the mechanism so that the rope will come out of the track and directly onto the pulley at the back of the mechanism (for details on which is return side and the correct pulley, see the rope path diagram).
- Tip!** Check the NME and make sure the return side of the track lines up directly with the pulley on the bracket. If it does not, you can make minor adjustments by splitting the difference between the two sides. However, if it is out of alignment by more than 1", call your distributor for help. Installing a misaligned unit could result in improper operation of the unit.
- With the mechanism in the correct position in the pit, and the track and pulleys in line as described above, secure the mechanism assembly in place by drilling through the pre-drilled holes and using the fixings supplied. It is essential that the base the mechanism be to be anchored to is strong enough. If there is any adverse movement, it must be rectified before carrying on with the rest of the installation.
  - On a cover 45' or less, the back pulley bracket should be level with the track without raising the pulley bracket. If it is not, raise the unit by placing shims underneath it. This will reduce the stress on the unit by reducing the angle at which the cover must move between the tracks.
  - Loosen the bolts on the adjustable pulley brackets on the drive and non-drive ends to allow movement from the front to back walls of the pit. Secure the top brackets on either end so that they are touching the walls and re-tighten the bolts.
  - Secure the brackets in position using the fixings supplied.

- Using the draw cord that should be threaded through the ducting from the plant room to the drive end of the pit, pull the hydraulic hoses through and fix them to the fittings on the DM.
- At this point an approved electrician using the wiring diagram supplied should wire the hydraulic motor into the mains.

N.B. Check for the following:

Are the ropes level as they travel from the tracks to the pulleys?

Does the roll up tube make a right angle with the tracks?

Is the unit mounted centrally in the pit?

Is the roll up tube level in the pit?

### 3. Cover Installation

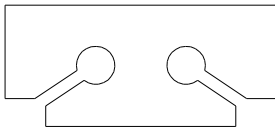
- Unroll the cover on the deck behind the mechanism so that the topside is facing up. Make sure the leading edge loop is on top.

**Tip!** At the factory, the cover is rolled from right to left, so always place the cover on the left hand side (standing behind the roller) of the mechanism and roll to the right.

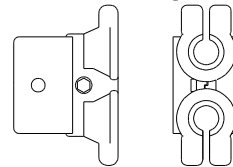
- Feed the rope into the feed guide (Fig 4.1).
- Pull the rope down the track channels, feeding it around the pulley at the end. Pull the rope through the rope feed guide and onto the mechanism, as per the rope path diagram.

**Tip!** It may be easier to feed the rope into the guide by pushing a piece of thin wire into the rope. Using this method, the rope can be pulled through the track channels and around the end pulley quickly and stay in the track.

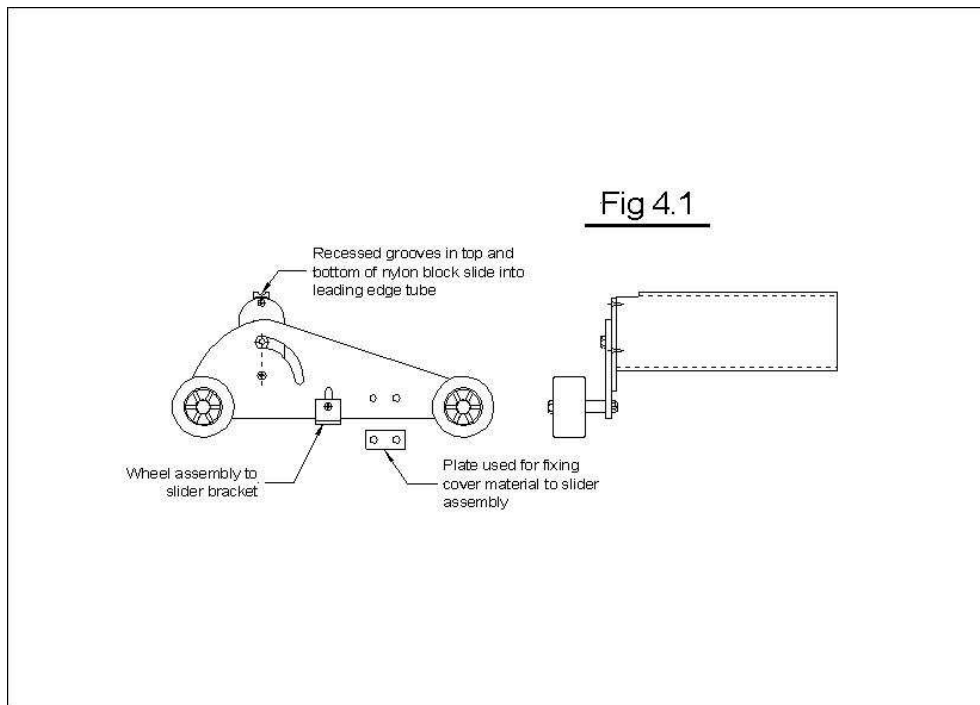
**Fig 4.0.1** – Horizontal flush track rope feed guide (end view)



**Fig 4.0.2** – Top track rope feed guide

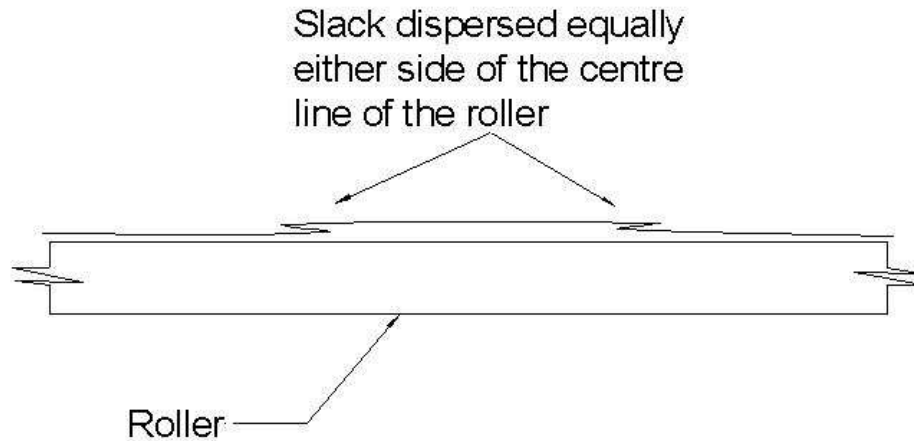


- Repeat the process for the non-drive (NME) side.
- Screw down the track and pulley end caps.
- Insert the leading edge tube into the material loop on the front edge of the cover.
- Pull the cover material webbing (white strip on edge of cover) approximately 6” into the track.
- Push the wheel/ slider inserts (Fig 4.1) into the end of the leading edge tube. The longer section of the wheel assembly faces the roller assembly. And screw the black slider in place – do not over-tighten, as this will restrict movement in the wheel assembly when the cover is running.



- ❑ Attach the cover to the wheel/ slider assembly by lifting the cover until it touches the back of the assembly where there are two pre-drilled holes. Carefully drill through the holes into the cover and fix it in position with the fixings provided. The cover material should be sandwiched between the inside edge of the wheel assembly and the aluminium plate with corresponding holes.
  - ❑ Drill a hole 1 1/64" (4.5mm) through the rope feed guide and track and fix it in position with the 1" x 10 self-tapping screws provided.
  - ❑ Pull both sides of the cover approximately 6" (152.4mm) into the tracks. It is important that both sides are into the tracks the same amount.
  - ❑ Go to the rope reels. Pull all the slack in the ropes out of the front of the unit so that the ropes are tight through the tracks and the loops. Before cutting the ropes be sure the cover is into the tracks about 6" (152.4mm) and is even across the front of the housing. Pull the ropes so that they just move each end of the leading edge. Put them together and ensure you have a minimum of 6' (1830mm) of rope to wrap around the reel. Now cut the rope. Heat the ends of the rope or wrap it with electrical tape to prevent fraying.
  - ❑ Using the 1/2" pan head screws supplied, screw through the rope about 1" on the drive side and 2" on the NME (this compensates for the stretch that may occur in the longer section of rope. Fix the ropes into the tapped holes in the respective rope reel sides.
  - ❑ While holding the ropes, run the cover to the 'closed' position to wind the ropes onto the reels. (When you run the cover at this point, the leading edge should begin to move at exactly the same time on both sides of the pool – if not, adjust the position of the screw in the rope on the side that started last.)
- Tip!** It is OK if the NME side of the cover starts slightly ahead of the drive side as it allows for any stretch that may occur in the rope. However, it should not be more than 1" ahead.
- ❑ Run the cover out over the pool.
- N.B.** If the pool has raised coping, ensure the cover material around the leading edge tube does not rub excessively.
- ❑ The cover is now ready to be fixed to the roller tube.
  - ❑ At the pit end, the end of the cover will be ready to be attached to the roller. Place the cover 1 1/2" over the end of the tube so that the outside lines up with the tracks on each side.
  - ❑ Approximately 2 1/2" from the end of the roller screw a 5/8" self-tapper, fixing the cover to the roller. Use the seam on the roller as a guide to keep the cover straight.
  - ❑ Gather all of the slack to the middle of the cover. Disperse it equally at two points, either side of the centre line of the roller (see diagram below).

Fig 5.2



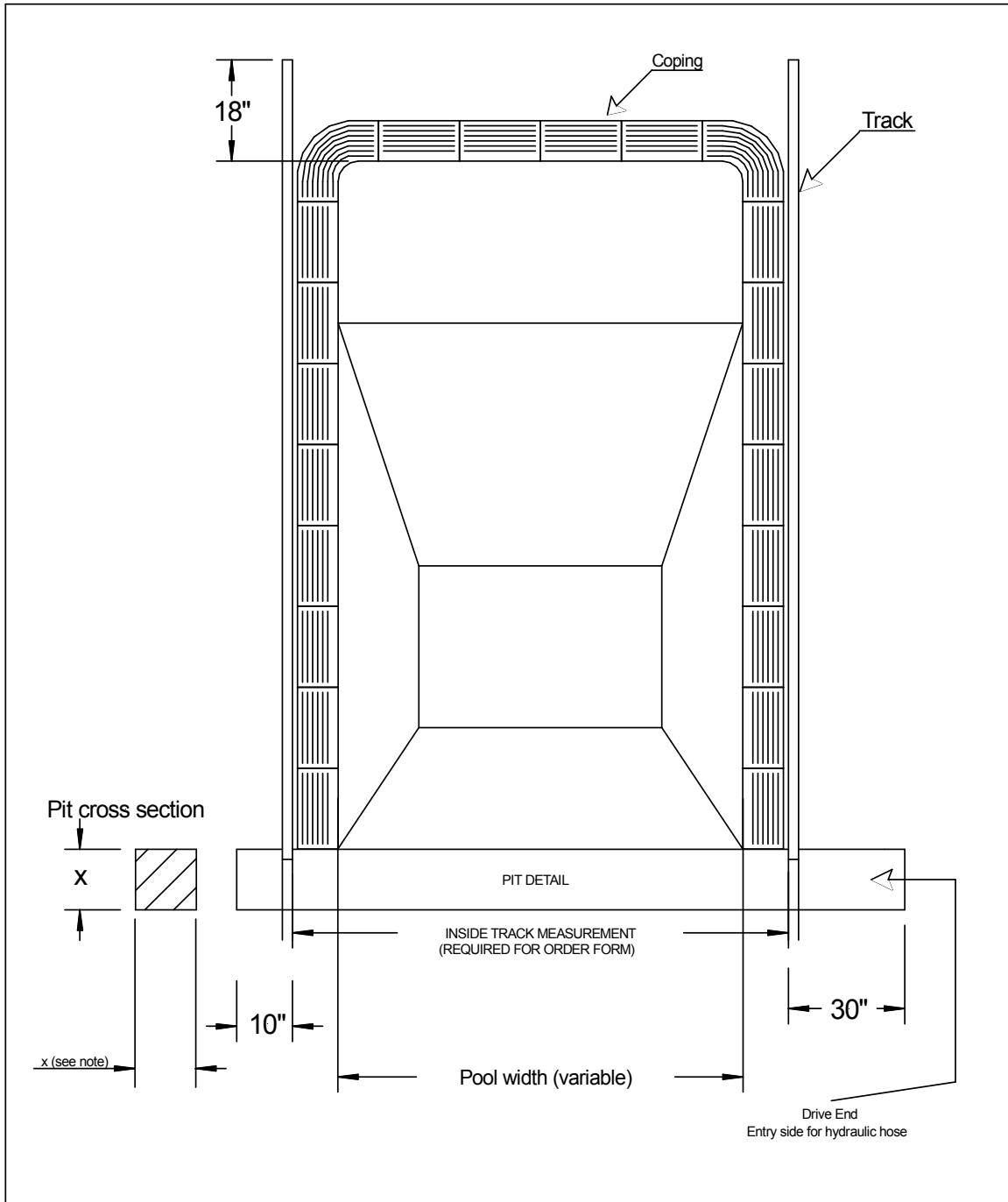
- ❑ Disperse all of the slack equally on either side of the centre hole in the roller. Fold the slack over and screw it to the roller.
- ❑ Using the screws remaining, screw the remaining sections of the cover to the roller equally, remembering to use the seam as a guide for straightness.
- ❑ Run the mechanism in the uncovered position so that the excess cover material is rolled up around the roll up tube. The material is now installed.
- ❑ Open the cover so that the wheel assembly is where you want it to stop. Place the L-shaped stop onto the guide, flush against the slider on the wheel assembly.
- ❑ Mark the centre line of the track, then using the pre-drilled holes in the stopper as pilot holes, drill through the track and anchor down using the fixings as provided.

## 4. Final Adjustments

- ❑ Check the brake mechanism on the rope reels. The rope reels should have enough friction to prevent them from freewheeling when running under stress. Note: The tension on the brackets is preset at the factory and normally will not need adjusting.
- ❑ Run the cover back and forth over the pool several times (at least 6 times to get any stretch out of the rope), making sure that it is operating properly. If necessary, make adjustments so that the cover is going out evenly and that it is operating smoothly.
- ❑ Ensure area is clean and tidy upon completion of work.

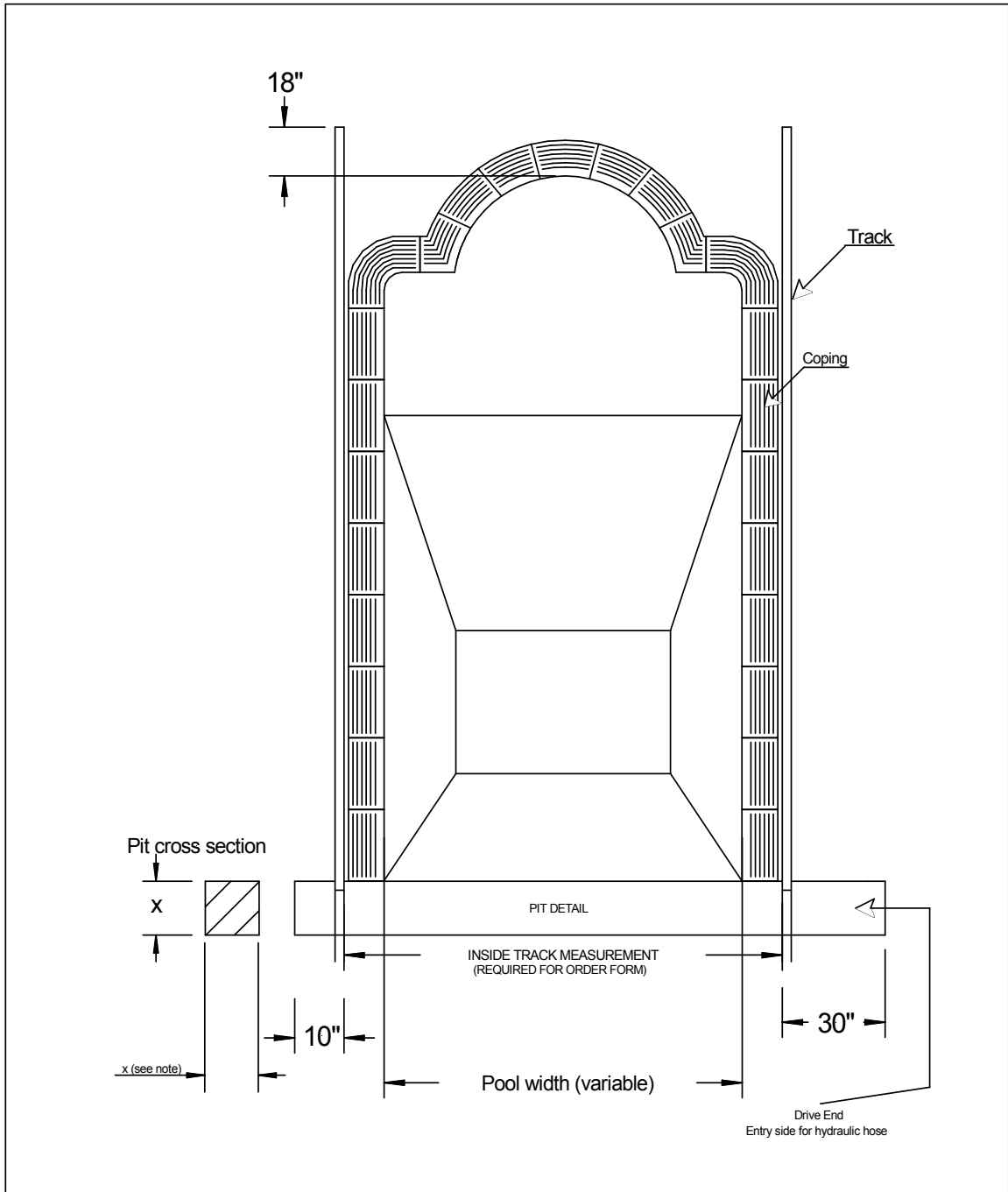
## Instructions to Homeowner:

- ❑ Instruct the homeowner on how to operate the cover with the key and how to stop the cover in the proper position.
- ❑ Instruct the homeowner on the use of the cover pump that should be in place at all times on the cover in an operating mode.
- ❑ Review the owner's instructions with the homeowner, and have them sign a worksheet stating they have been instructed and the installation has been completed to their satisfaction.



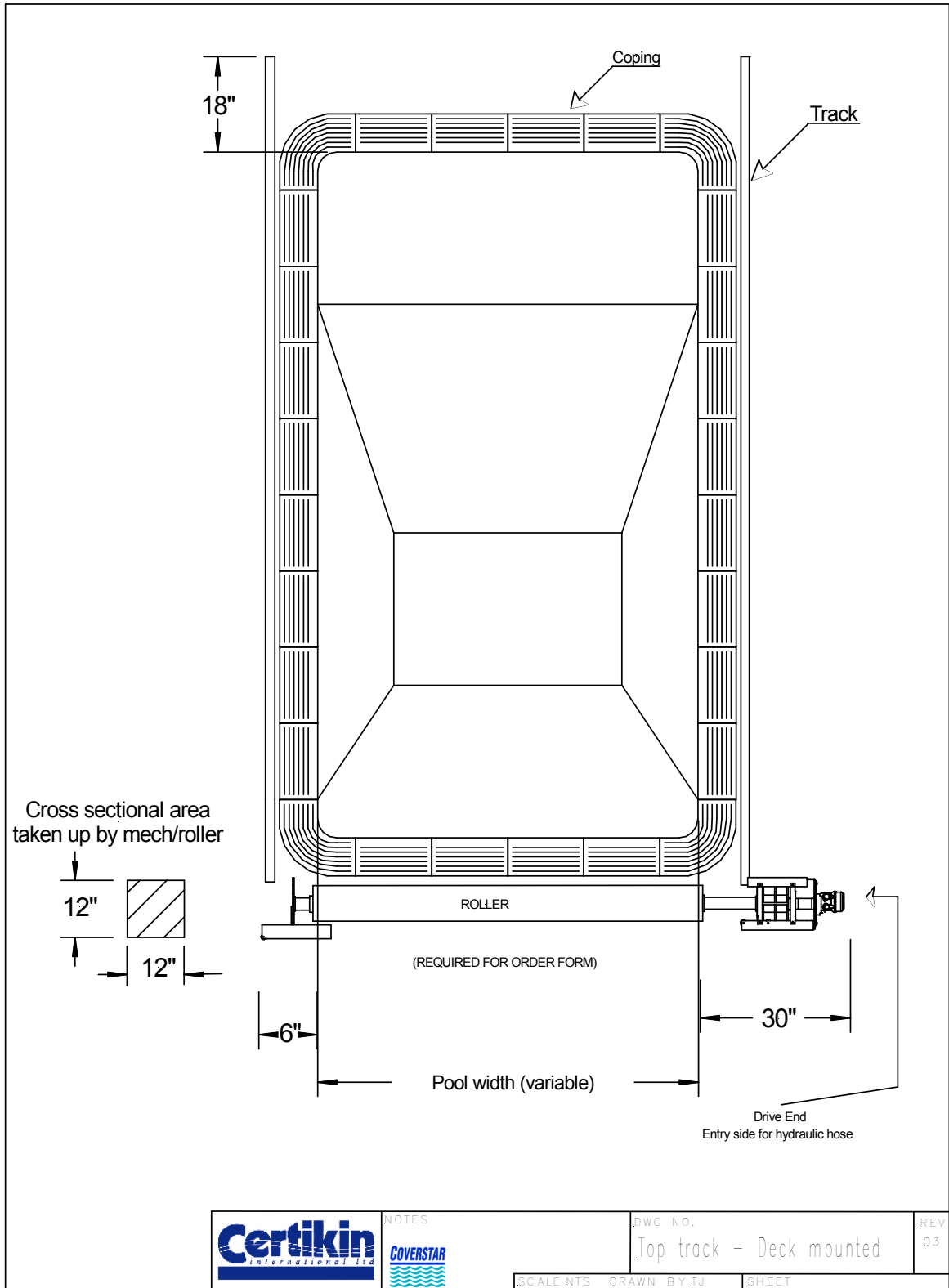
Note:  
 x is relative to pool length:  
 Up to 40' long, x = 12"  
 40-50' long, x = 13"  
 over 50' long, x = 15"

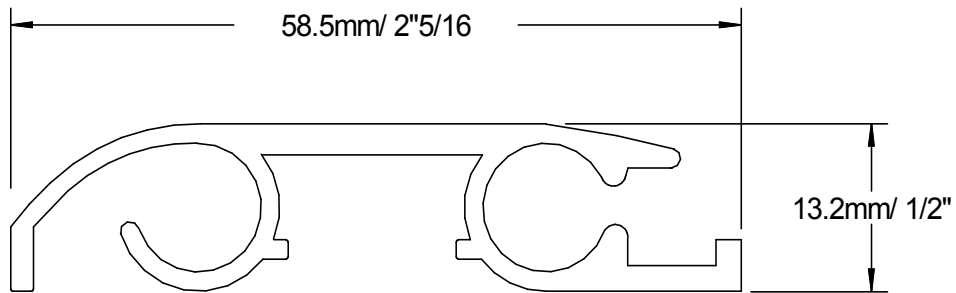
		NOTES	DWG NO.	REV
			Top track - Pit mounted	0.3
SCALE NTS		DRAWN BY JJ	SHEET	



Note:  
 x is relative to pool length:  
 Up to 40' long, x = 12"  
 40-50' long, x = 13"  
 over 50' long, x = 15"

 	NOTES	DWG NO.	REV
		Top track - Pit mounted	03
SCALE NTS. DRAWN BY JJ		SHEET	





NOTES



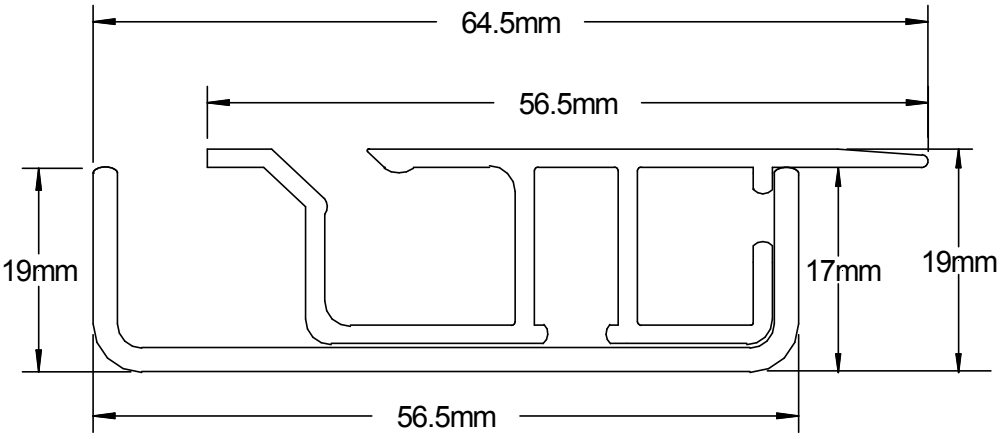
DWG. NO.

Topmount track guide (cross section)

REV

02

SCALE: 1:1 DRAWN BY: J.J. SHEET



NOTES

DWG NO.

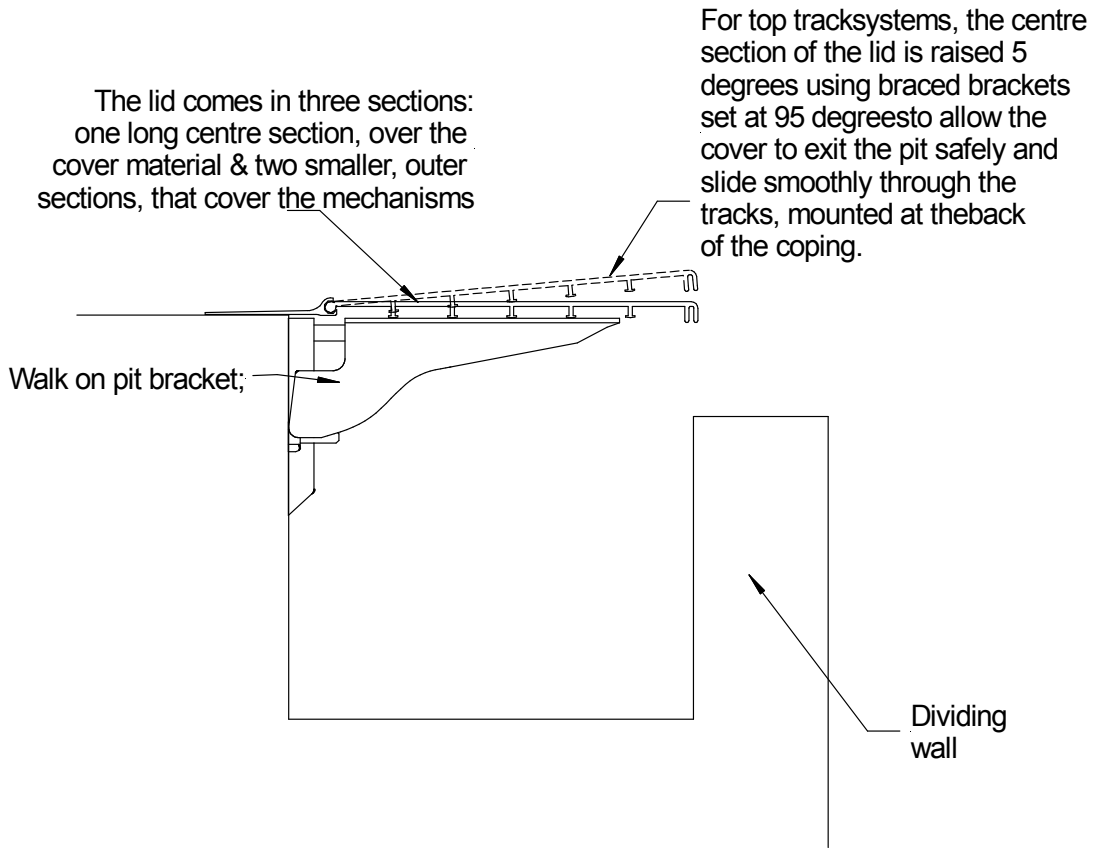
Recessed horizontal topguide

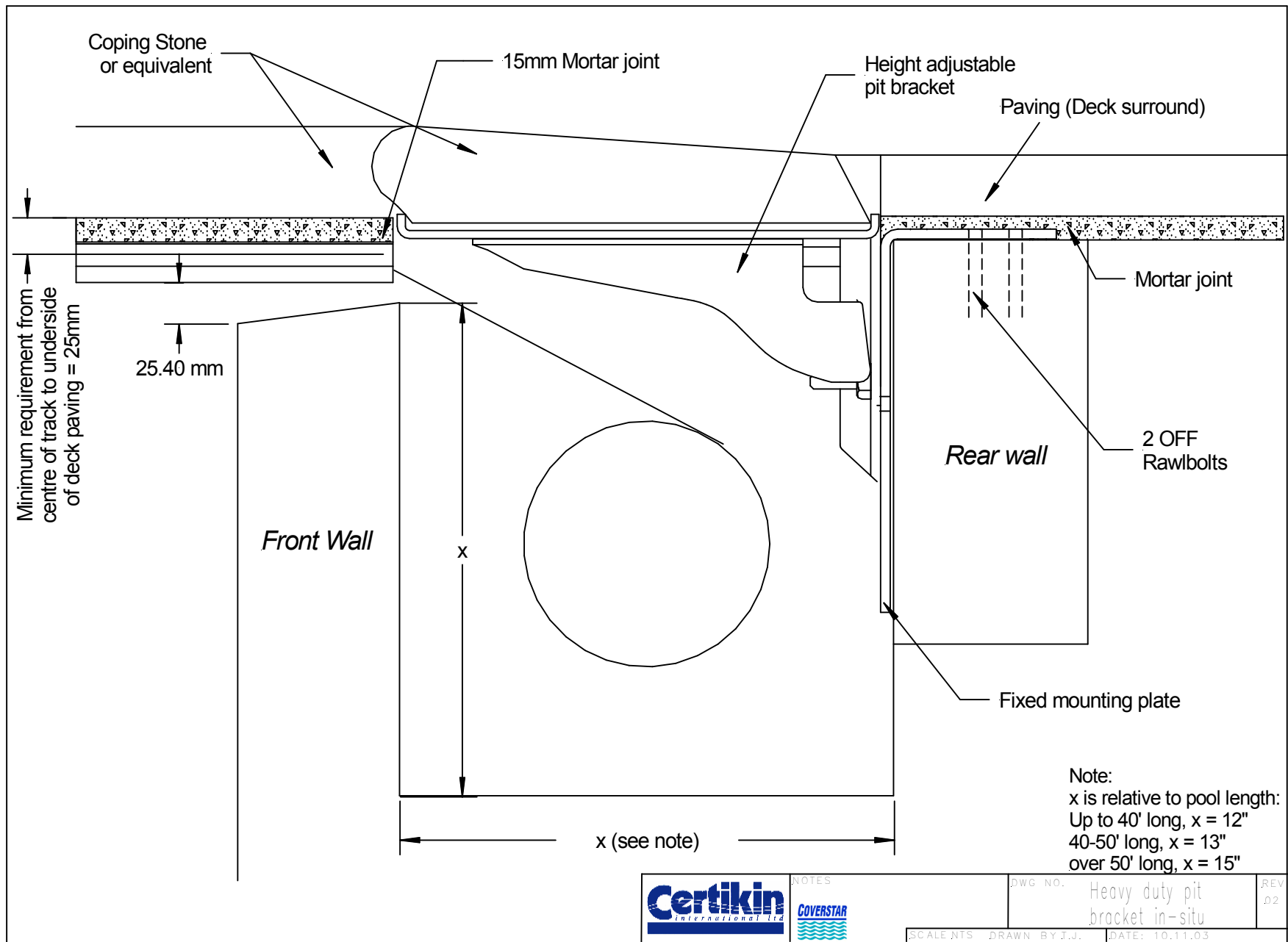
REV

D2

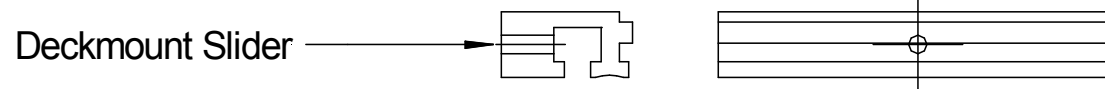
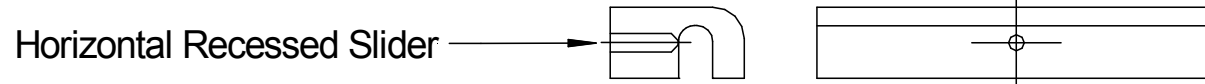
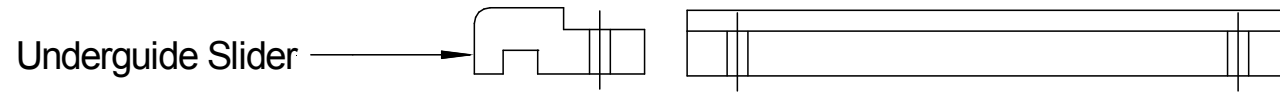
SCALE: 1:1 DRAWN BY: T.J.J. SHEET

## Coverstar Standard Aluminium Lid



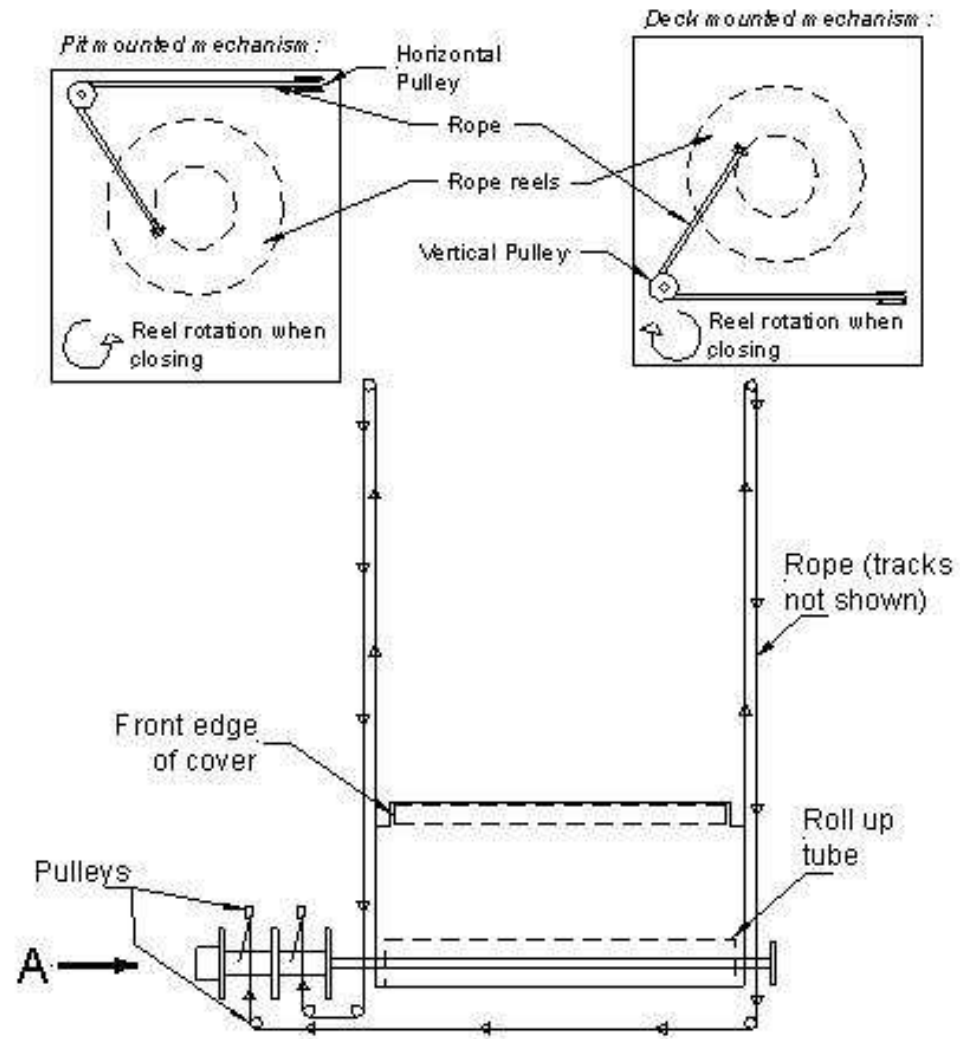


# Slider types



# Rope Path Diagram

*View on A:*



## Troubleshooting:

### Cover does not run square:

In most cases if the ropes are properly adjusted, the system will run perfectly. If however, in a few cases, after adjusting the rope, the cover still does not go out and come back square then go through the following list for helps. One important item to keep in mind is has the cover run square before or has it never run square? If it has never run square, then check "Items to check".

#### GENERAL

1. Does the cover start out evenly? Pull cover all the way off of the pool and pull out approximately one foot. Is it out an equal distance on each side of the pool? If not, adjust the rope length on the side that is lagging.
2. As the cover goes out, does there appear to be equal tension on each rope?
3. As the cover goes out does one side go out ok for a distance then lag?
4. Does cover have enough clearance on all sides? Check webbing for signs of wear from rubbing.
5. Are the sliders binding?
6. Is the track clear of sand, mud, etc?
7. Are all pulleys operating properly?
8. Is the track bent?
9. Is the guide opening of the correct size?
10. Are the ropes the same size?
11. Are the ropes the same kind?
12. Is the webbing rolling up on the take-up tube (instead of off of the tube)?
13. Is the webbing folding under as the cover rolls up?
14. Can you pull out the cover by hand? Is one side harder to pull than the other side?
15. Is slider tilted at an angle causing binding?
16. Is cover pinned on the roller square?
17. Do leading edge inserts move in and out freely the complete length of the pool, or is the leading edge too long, causing them to bind?

#### ITEMS TO CHECK

1. Track length motor side & non-motor side. Are they the same?
2. Is the distance from end of track to centre of rollup tube **motor end** the same as the distance from end of track to centre of rollup tube **non-motor end**. It should be.
3. Is the track width at mechanism end, centre & shallow end of the pool the same?
4. Distance from bottom of track to top pulley on both sides
5. Distance from inside of track to edge of housing.
6. Is the lowered bond beam the same width on both sides of the pool?

#### UNDERGUIDES/ RECESSED TOPGUIDE

1. Is cover rubbing against the side or bottom of the box or a lid bracket?
2. Is rope from non-motor end catching under a lid bracket?
3. Is take-up tube and system level?
4. Is the cover wearing the black nylon guide feeds evenly (if the guide feeds are stainless steel this will be hard to determine)?

## Troubleshooting:

### Repairing Heat Sealed Webbing

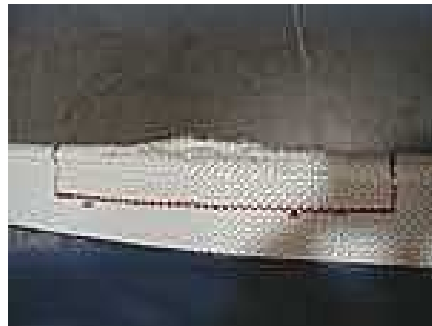
This method is recommended when repairing a damaged area in the webbing that is not necessarily in the front corner. Care is to be taken to not overlap or create open places in the webbing. This repair requires webbing and a method of sewing.

**1. Cut the damaged part of the webbing out leaving the rope intact.**

- Make a mark on the webbing that is 3/4" from the fabric edge of the webbing running parallel to the rope.



- Mark the webbing at a right angle with the rope at the point where the webbing is good on both ends of the damage.



- Cut the webbing off along the marks being careful to not damage the rope
- All edges should be square and clean



- 2. Cut a piece of webbing to the same length as the area that was cut from the cover.**
- 3. Fold the webbing around the rope and along the length of the removed area.**



**4. Sew the webbing in place**

- Stitch along the side of the rope for the full length of the repair plus 2 inches past each end of the repair reaching into the existing webbing.
- Run two rows of stitching for the full length so that both rows serve to hold the webbing to the cover.
- Stitch across the two points where the new webbing meets the existing webbing. This is to keep the joint closed so that the guide feed does not push through it.

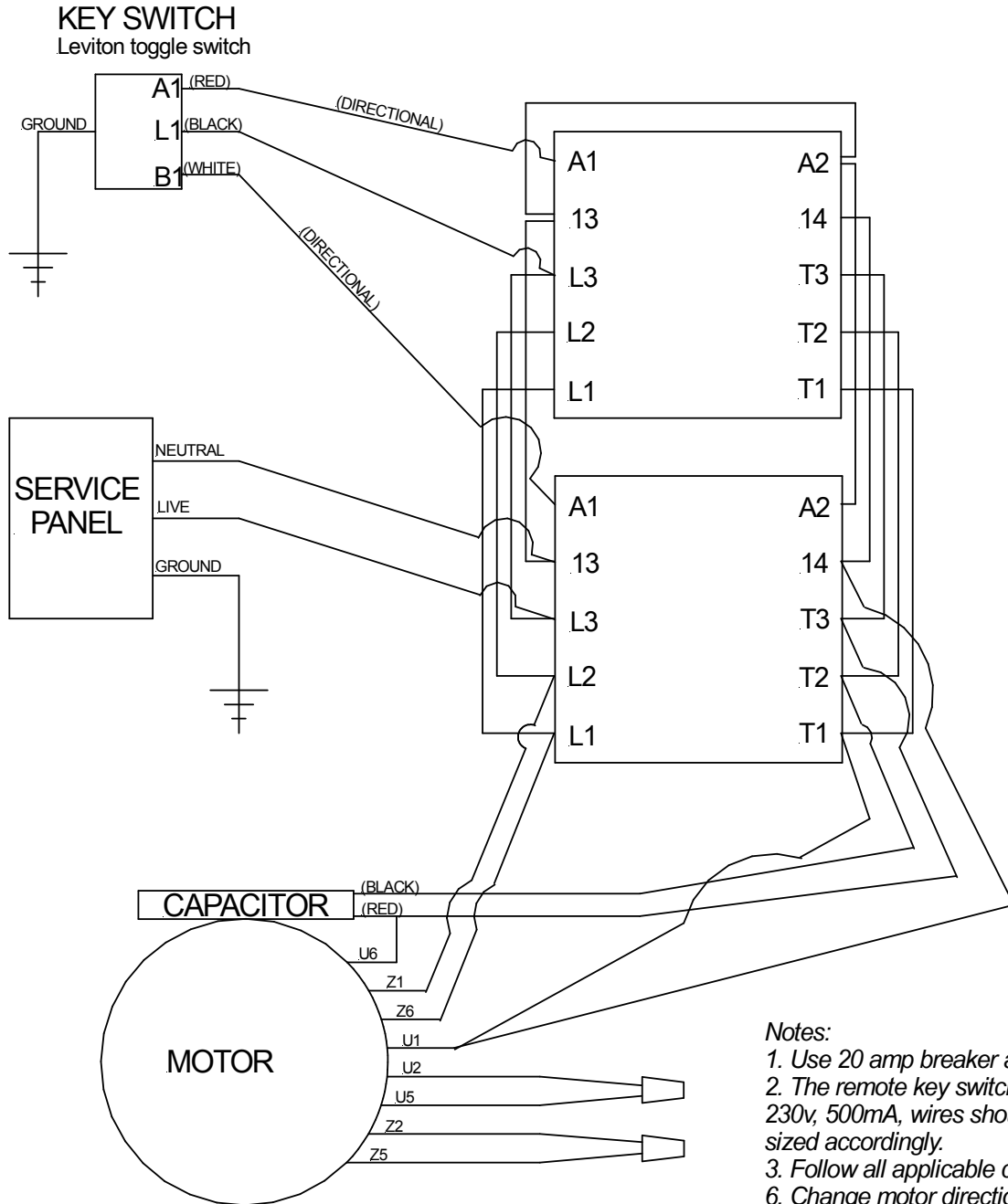


- 5. Ensure that all stitching is snug and that the webbing does not overlap in the area where it must slide through the guide feed**

4-10-04

# 230V HYDRAULIC - EUROPEAN WIRING

## HYDAC with externally mounted capacitor



- Notes:**
1. Use 20 amp breaker at panel.
  2. The remote key switch carries 230v, 500mA, wires should be sized accordingly.
  3. Follow all applicable codes.
  6. Change motor direction by exchanging the directional wires either in the control box or at the keyswitch. Exchanging hydraulic hoses will also change direction.